

FPT Models 30-64F Sensor and Control Panel Pre-Installation Planning and Review

Sensor and Control Panel Considerations

- Use the metal of the cooling tower as a barrier from EMF interference (radar, cell, antenna or radio towers).
- Do NOT use the same power source or ground circuit of a VFD.
- Do NOT run the sensor cable within 3" of VFD control wires or high voltage lines.
- If the control panel and/or sensor cannot be out of site of a VFD, then maintain at least 15 feet from VFD panels, wires.

Rules for High and Low voltage circuits

- Maintain at least 3" spacing between the sensor cable and high voltage lines.
- Do NOT run the sensor cable in the same conduit with high voltage lines.
- When crossing high voltage lines, cross them perpendicularly.
- Do NOT coil excess sensor cable.

Sensor Cable Length

The sensor cable comes in 50-foot increments, starting at 50ft. Order the cable longer than you need it. The sensor cable should be cut to fit. Be sure to leave enough slack (1 ½ times the length of the longest rod) in the sensor cable in the event the sensor needs to be removed for maintenance or inspection. If a sensor cable splice is necessary, contact Waterline Controls to order a splice box enclosure.

- Install the sensor cable in earth grounded metal conduit separate from the earth grounded metal electrical conduit housing high voltage lines. In those cases where running separate conduit is not plausible then follow the rules for high and low voltage circuits. Do NOT zip tie the sensor cable to conduit carrying high voltage lines.

Control Panel

- Provide a dedicated 15 to 20-Amp circuit to the control panel. Do NOT share the ground or neutral with other circuits and by no means should the circuit for a VFD be used.
- We recommend placing the control panel as close to the cooling tower as possible, keeping it above the water basin and out of sight of any Variable Frequency Drives (VFD).
- The control panel should be mounted in a convenient location where water spray will not impinge upon the unit and at a height above the tank overflow level to prevent water from feeding into the sensor wire conduit.
- Plan to mount the control panel where the low voltage wire crosses (perpendicularly) the least number of high voltage circuits.

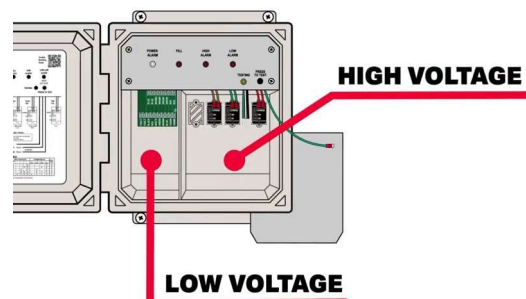

Installation Overview

Go over the Pre-Installation Planning and Review

- Step 1: Determine location and placement of control panel
- Step 2: Planning for connections
- Step 3: Mounting the control panel
- Step 4: Mounting the sensor
- Step 5: Routing the sensor cable to the control panel
- Step 6: Connecting the sensor wires to the control panel
- Step 7: Connecting BMS/BAS/Fire Panel wires
- Step 8: Providing power to control panel
- Step 9: Connecting controlled devices (Valves & Pumps)
- Step 10: Testing the control panel

Installation Steps

Step 1: Determine location and placement of control panel

We recommend placing the control panel as close to the cooling tower as possible, keeping it above the water basin but out of line of sight of any Variable Frequency Drives (VFD). If the distance exceeds the length of the sensor cable, contact Waterline Controls to order a splice kit.

Step 2: Planning for wiring connections

The control panel has low voltage and high voltage compartments. All connections to the control panel should be in their respective compartment using the knockouts at the bottom of the control panel. DO NOT bring wires into the sides or top of the control panel.

- **Install sensor wires and BMS connections in the low voltage compartment using separate conduit. Use knockouts at the bottom of the control panel.**
- **Install power and valve connections in the high voltage compartment using separate conduit. Use knockouts at the bottom of the control panel.**

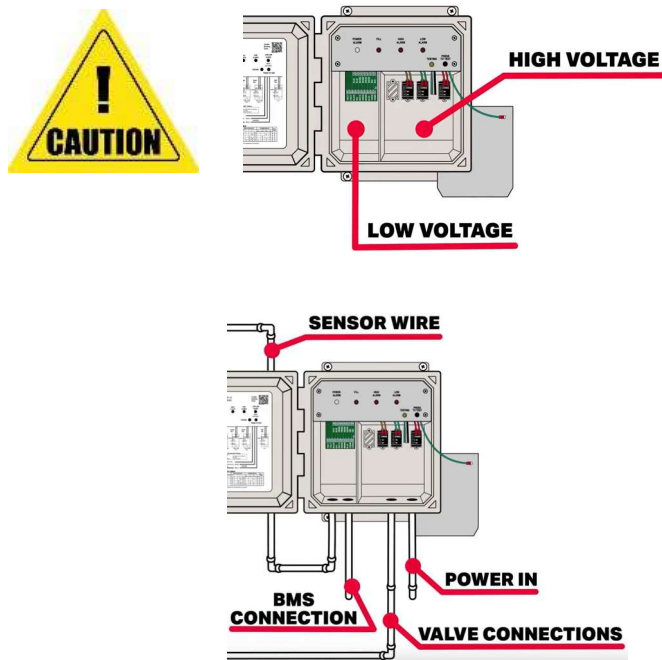

CAUTION: The sensor cable carries low voltage signals from the sensor to the controller. Erroneous or false signals can occur near high voltage lines or in the presence of VFDs.

- **Use grounded conduit separate from high voltage lines.**
- **Do not run in parallel or within 3" of high voltage lines.**

If a beacon is needed, use a low voltage connection, or ensure any high voltage connections are kept away from the PCB.

Step 3: Mounting the control panel

The Waterline Controls panel should be mounted in a convenient location where water spray will not impinge upon the unit and at a height above the tank overflow level to prevent water from feeding into the sensor wire conduit.

The control panel comes with two mounting flanges and four machine screws. Attach the flanges to the back of the control panel using the provided machine screws. Securely mount the panel to the wall with appropriate hardware.

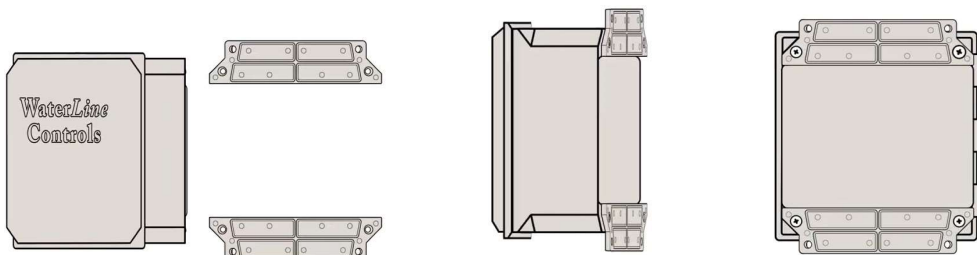

Step 4: Top Of Tank Sensor Mounting

The following pertains to the use of the Top of Tank mounting. Your installation may require the use of a different mounting option.

Top of Tank Mount

You must have a 4" Female NPT threads at the top of the tank.

The sensor assembly consists of the sensor, coupler, and pipe.

Slide the sensor assembly up or down through the mounting assembly and tighten flexible coupling when at the right height.

CAUTION There are two air vent holes in the PVC pipe. Make certain these air vent holes are not obstructed in any way. They must be clear for the sensor assembly to properly function.

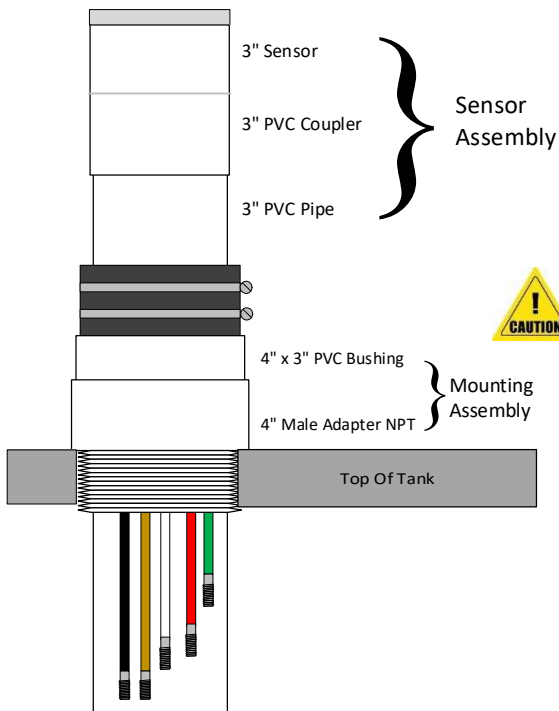

Step 5: Routing the sensor cable to the control panel

Route the sensor cable along an appropriate path and determine if the length needs to be shortened.

The cable may be cut to a shorter length but must not be spliced without using Waterline Controls splice enclosure. Be sure to leave enough slack in the cable in the event the sensor needs to be removed for maintenance or inspection.

TIP: The sensor cable slack should be about 1 1/2 times the length of the longest rod.

Install the sensor cable in an earth grounded metal electrical conduit. Using a watertight connector, connect to the bottom of the Waterline Controls panel below the low voltage compartment.

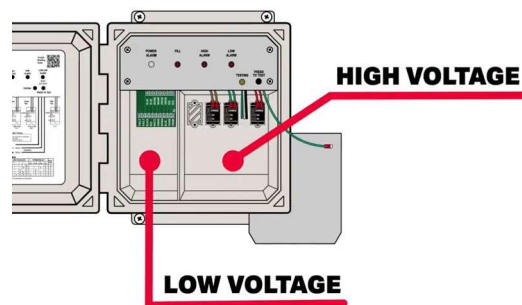

Step 6: Connecting the sensor wires to the control panel

Grounding Sensor Wires

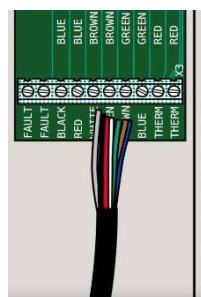

Cable shield: Connect black sensor wire and cable shield wire to the BLACK input terminal.
Signal grounding should be isolated from other grounding systems.

Step 7: Connection BMS/BAS/Fire Panel wires

The dry contact sets included in the Waterline Controls panel can be used as an aid to remotely signal the Building Automation or Management System of the status of the control panel's output functions.

- ! The dry contacts are Form A SPST relays rated 0.5A @ 60 VAC/DC

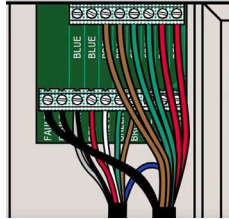

- ! Refer to your specific control panel model for details on specific output functions and BMS/BAS connections.

Step 8: Providing power to the control panel



ELECTRICAL SHOCK HAZARD

Disconnect power before installing or servicing this product. A qualified service person must install and service this product according to applicable electrical codes.

Provide a dedicated 20-Amp circuit to the control panel. Do NOT share the ground or neutral with other circuits and by no means should the circuit for a VFD be used.

Power wires should only come through the knockouts at the bottom on the high voltage side of the controller. DO NOT bring high voltage wires through the top or sides of the controller.

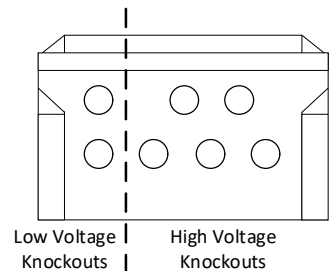

Bottom Side View

For 110VAC connections:

- Connect Line to the Black wire.
- Connect Neutral to the White wire.
- Connect the facility ground to the Green wire.

For 220VAC connections:

- Connect Line 1 to one of the Black wires.
- Connect Line 2 to the other Black wire.
- Connect the facility ground to the Green wire.

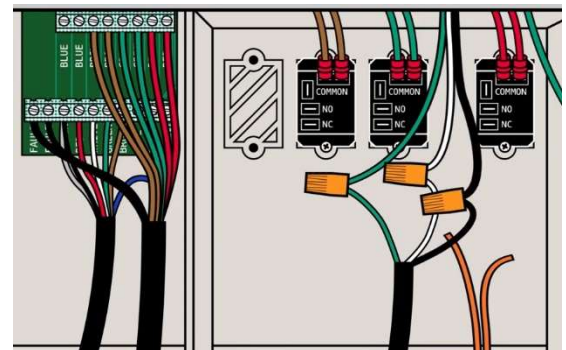

Step 9: Connecting controlled devices (Valves & Pumps)

The power relays are Form C SPDT rated max. 120VAC @ 40A.

EXAMPLE FOR CONNECTING A 110VAC SOLENOID VALVE

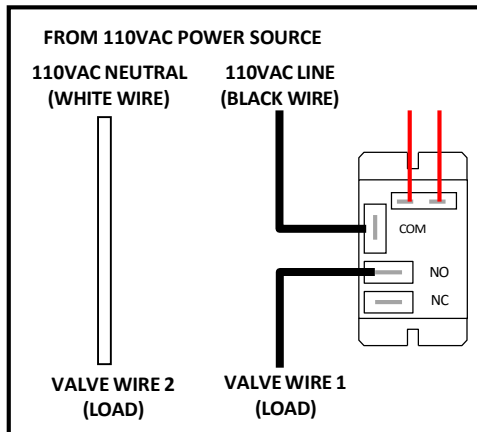

CONNECT 110VAC LINE TO COM OF RELAY
CONNECT VALVE WIRE 1 TO NO OF RELAY
CONNECT VALVE WIRE 2 TO 110VAC NEUTRAL

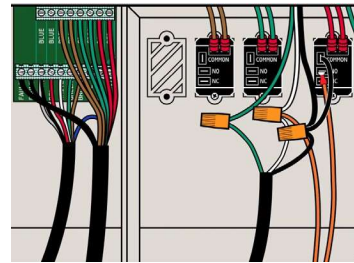

Step 10: Testing the control panel

1. Press and hold the HOLD TO TEST push button and release once the TESTING LED is lit. The TESTING LED will remain on until the test function is complete.
2. The controller automatically sequences through the functions and concludes with five flashes of the Power/Fault LED.

NOTE: This test will take approximately 2 minutes and cannot be interrupted. It is intended to test the function of the dry contacts and power relays with devices connected.

Maintenance

Cleaning the probes

Use warm soapy water on each sensor probe to remove any algae or debris. This should be performed at least once every six months.

Troubleshooting

Please use our on-line troubleshooting flow to resolve the most common issues.

<https://waterlinecontrols.typeform.com/to/Jnl1NN>



Or use our Troubleshooting QR code.

Use the QR code to access the Action links on our web site.

Problem/Issue	Possible Cause	Action
Power LED Off	Loss of Input Power Source	Check if main breaker tripped
		Check for faulty wiring connections
	Power Surge or Lightning Strike	<i>Controller Test</i>
High Alarm LED constantly on	Defective PCB	<i>Controller Test</i>
Power/Fault LED flashing	Probe Sequence Fault	<i>Clean Sensor Probes</i>
		<i>Sensor Test</i>
		Check for good extension rod connections
	Damaged Sensor Cable or Wires	<i>Sensor Probe Continuity Test</i>
	Breather Hole Obstruction	Clean PVC Stilling Chamber
Tank overflowing	Defective Solenoid Valve	<i>Solenoid Test</i>
	Defective Power Relay	<i>Power Relay Test</i>
Tank will not Fill	Loss of Input Power Source	Check if main breaker tripped
		Check for faulty wiring connections
	Power Surge or Lightning Strike	<i>Controller Test</i>
	Defective Solenoid Valve	<i>Solenoid Test</i>
	Defective Power Relay	<i>Power Relay Test</i>
Intermittent False High Alarm	High Voltage interference	<i>Sensor Cable Installation</i>