



# WLC-9100D-110VAC SUBMITTAL

## Duplex Pump Down (Alternating On/All Off) with High Alarm

**NEW MORE RELIABLE TECHNOLOGY** by Waterline Controls® FOR SPECIFYING ENGINEERS WITH A TESTED & PROVEN TRACK RECORD in MRO APPLICATIONS for 10+ years.

Our controls can **REPLACE ALL SENSOR & CONTROL TYPES** in ALL water based applications.

We **ARE NOT** similar to float switches, capacitive, conductive, ultrasonic, or pressure transducers. We **ARE** more reliable, easy to operate, & last longer.



### Features::

- 5 Year Limited Warranty
- NEMA 4x control enclosure
- Intuitive LED indicators
- Dry contact connections for BMS, BAS, or fire panel
- Fully automated by microprocessor
- Color coded sensor rods & wires for intuitive installation
- Test Push-button for output devices
- Power relays for valves, pumps, etc.
- Optional temperature sensor controlled relay
- Controls can be mounted in equipment room w/ sensor wired remotely
- Push-button for relay test
- Modular construction
- Extendable sensor probes

### Benefits:

- Permanently eliminate float switches
- Less than 1% failure rate in the field
- Intrinsically safe - no high voltage in water
- Never needs recalibration
- Fully Commercialized
- Sensor will not plate, foul, or deteriorate
- Water quality does not matter
- Flexibility in design to meet any scenario
- Minimal maintenance
- Stand-alone controls
- Only moving parts are replaceable relays

# WLC-9100D-110VAC SUBMITTAL

## Duplex Pump Down (Alternating On/All Off) with High Alarm

### FUNCTIONAL DIAGRAMS

#### STATUS INDICATORS (LED)

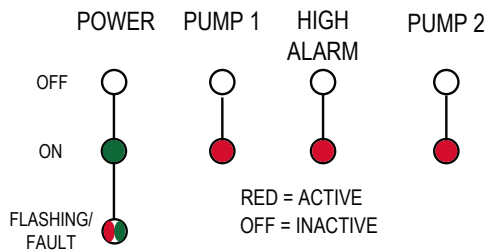

The Power LED will be off on power loss, Green when powered on and Flashing on Fault conditions.

The Status Indicator LEDs will be Red when active and off when inactive.

#### LOW VOLTAGE DRY CONTACTS TO BUILDING AUTOMATION

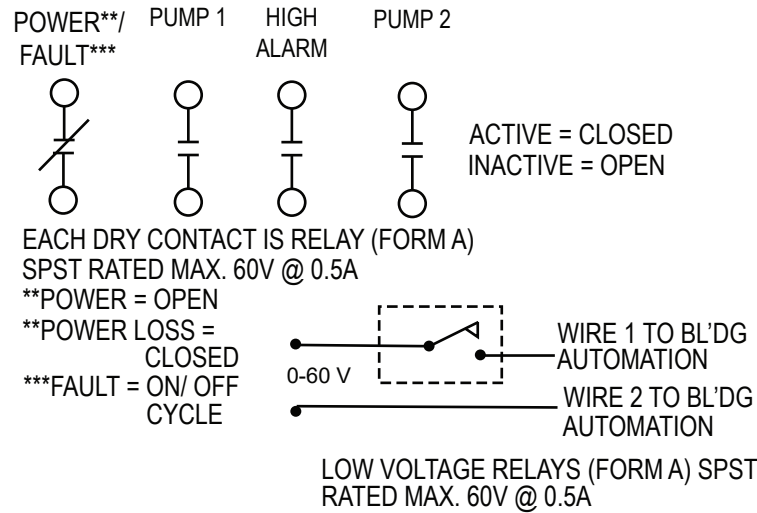

#### HIGH VOLTAGE POWER RELAYS

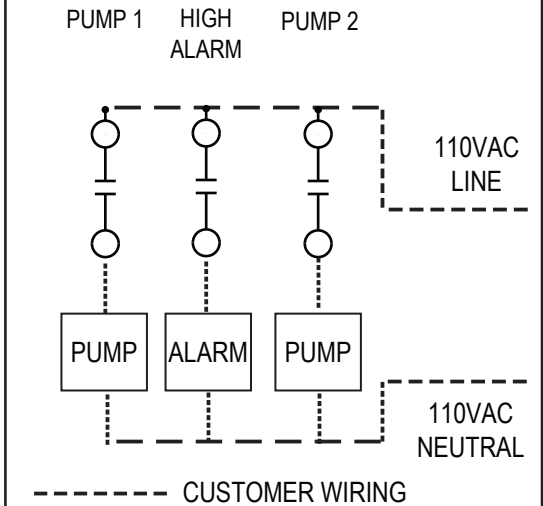

Example of 100VAC devices wired to power relays

### PRODUCT FUNCTION TRUTH TABLE

MODEL	BMS DRY CONTACTS					POWER RELAY				SELF TEST
	FAULT/ POWER LOSS	PUMP 1	HIGH ALARM	PUMP 2	BAS WIRES	PUMP 1	HIGH ALARM	PUMP 2		
WLC-9100D	X	X	X	X	8	X	X	X	X	

**Toll Free: 888-905-1892**  
[www.waterlinecontrols.com](http://www.waterlinecontrols.com)  
 Email: [info@waterlinecontrols.com](mailto:info@waterlinecontrols.com)

# WLC-9100D-110VAC SUBMITTAL

## Duplex Pump Down (Alternating On/All Off) with High Alarm

### PHYSICAL WIRING CONNECTIONS

**LOW VOLTAGE DRY CONTACTS TO BUILDING AUTOMATION RATED MAX. 60V @ 0.5A**

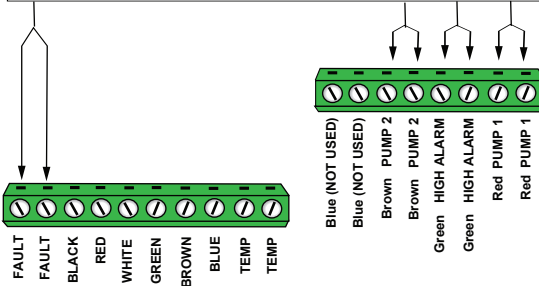

SENSOR PROBE WIRES

Front

Back with Mounting Bracket

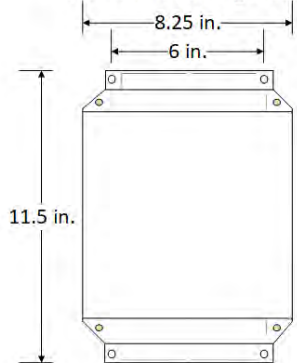
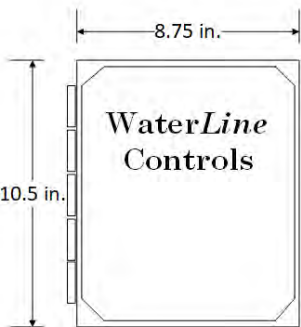

Bottom Side View

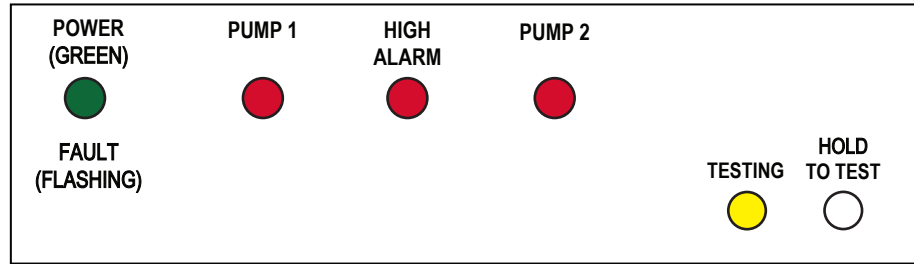
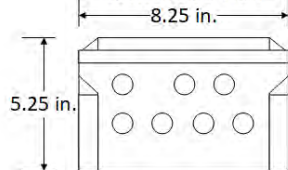

#### CONTROL UNIT RATINGS

VOLTS: 110 VAC (50/60 HZ)  
AMPS: 0.5 AMPS  
WATTS: 55W

220VAC ALSO AVAILABLE

#### HIGH VOLTAGE POWER RELAYS

Form 1C - SPDT  
Rated max.: 120 VAC @ 30A  
All relays are typical  
Relay terminals are 1/4" male spade

Brown Wire Pair

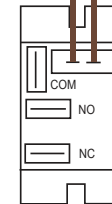

Pump 2 Power Relay

Green Wire Pair

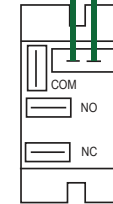

High Alarm Power Relay

Red Wire Pair

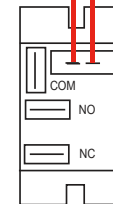

Pump 1 Power Relay

110 VAC  
Black - Line  
White - Neutral  
Green - Ground

#### EXAMPLE FOR CONNECTING A 110VAC PUMP

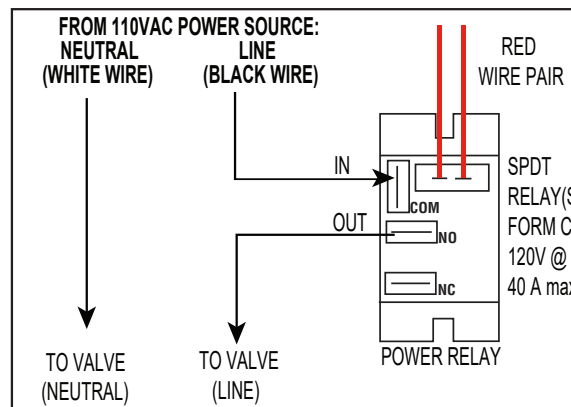

**Toll Free: 888-905-1892**  
[www.waterlinecontrols.com](http://www.waterlinecontrols.com)  
Email: [info@waterlinecontrols.com](mailto:info@waterlinecontrols.com)

# WLC-9100D-110VAC SUBMITTAL

## Duplex Pump Down (Alternating On/All Off) with High Alarm

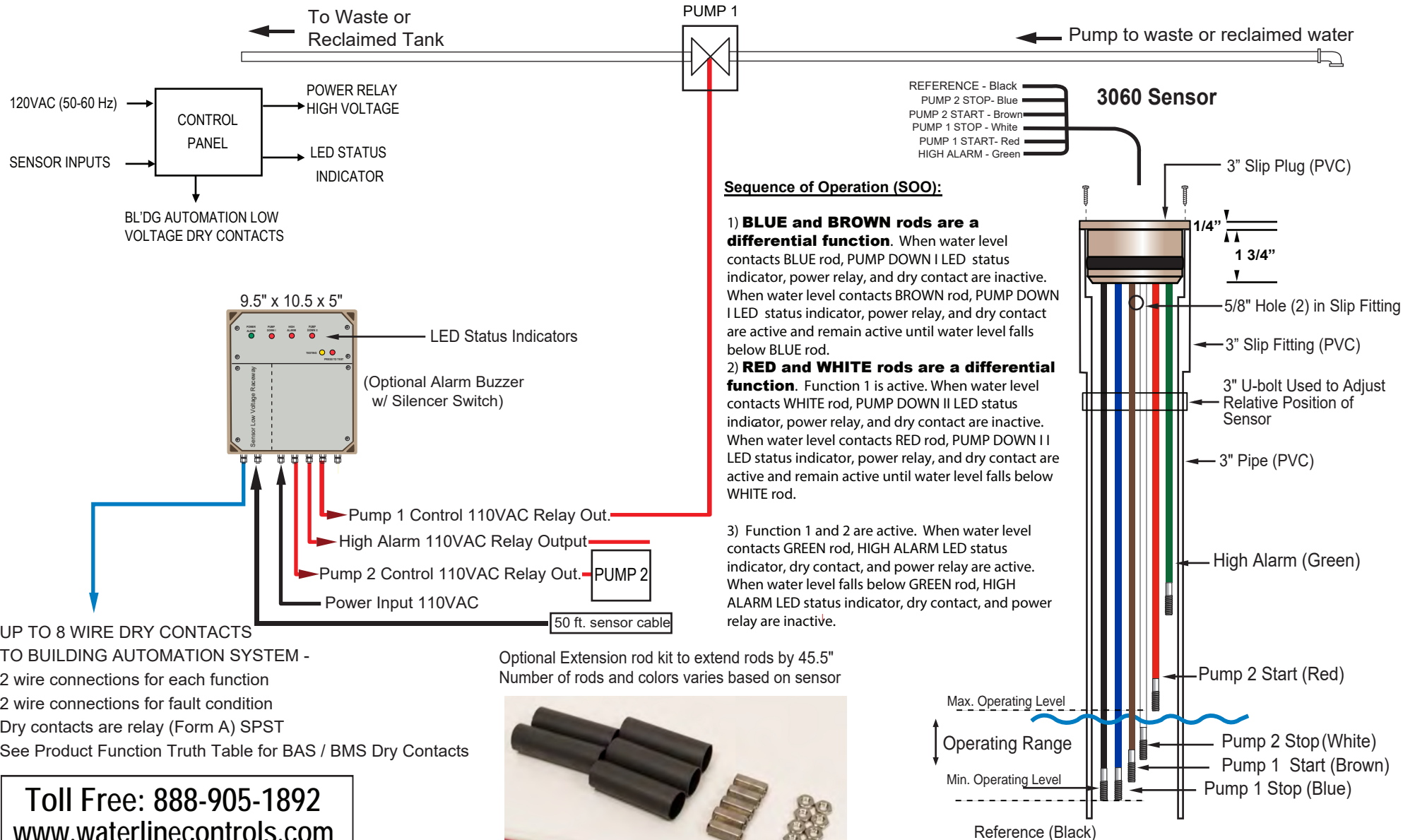

Toll Free: 888-905-1892  
 www.waterlinecontrols.com  
 Email: info@waterlinecontrols.com

# 3060 Sensor Approval

CUSTOMER	Standard Cable length is 50 ft. Available in 50ft increments up to 350 ft. Over 350 ft. please call
PO#	All rods are 304 stainless steel with 1/4-20 threaded ends. Sensor rods can be extended using an Extension Rod kit accessory. Sensor rods & wires are Intrinsically safe with circuit limited signals.
SO#	
SHIP DATE	
QUANTITY	
CABLE LENGTH (ft.)	

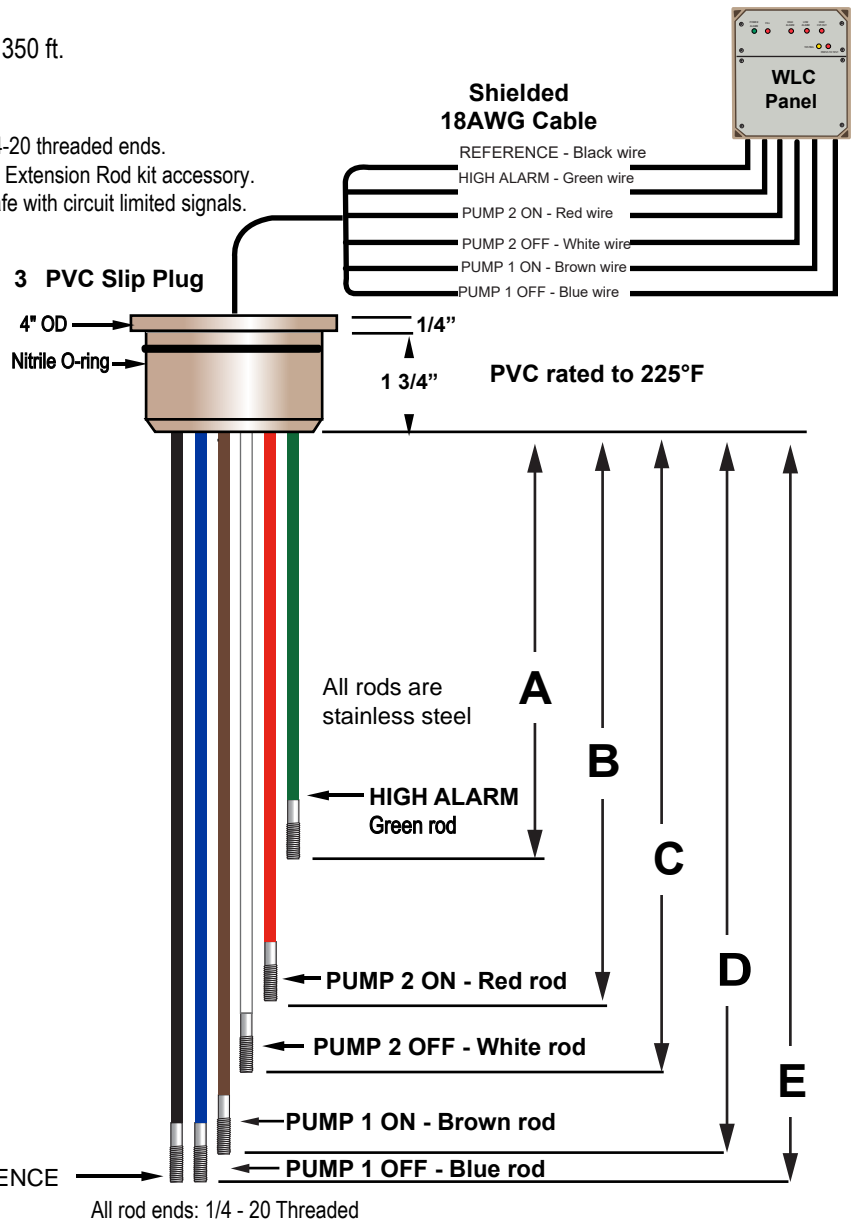

Waterline Controls  
P.O. Box 12544  
Scottsdale, Arizona 85260  
Toll Free: 888-905-1892  
info@waterlinecontrols.com  
www.waterlinecontrols.com

Custom rod length requests should be measured from where the bottom of the sensor cup will be seated after mounting, down to the required function or alarm level(s) in inches. Be sure to take into account any riser pipes or man-way risers

Fill Custom in as needed

SENSOR		LENGTHS	
		Standard	Custom
Green	HIGH ALARM	A	10 3/8"
Red	PUMP 2 ON	B	14"
White	PUMP 2 OFF	C	15 1/2"
Brown	PUMP 1 ON	D	16 3/8"
Blue	PUMP 1 OFF	E	17"
Black	Same length as longest rod		

Name: \_\_\_\_\_

Company: \_\_\_\_\_

Signature: \_\_\_\_\_

Date: \_\_\_\_\_

## Sensor and Control Panel Pre-Installation Planning and Review

### Sensor and Control Panel Considerations

- Use the metal of the cooling tower as a barrier from EMF interference (radar, cell, antenna or radio towers).
- Do NOT use the same power source or ground circuit of a VFD.
- Do NOT run the sensor cable parallel to VFD control wires or high voltage lines.
- If the control panel and/or sensor cannot be out of site of a VFD, then maintain at least 15 feet from VFD panels, wires.

### Rules for High and Low voltage circuits

- Maintain at least 3" spacing between the sensor cable and high voltage lines.
- Do NOT run the sensor cable in the same conduit with high voltage lines.
- When crossing high voltage lines, cross them perpendicularly.
- Do NOT coil excess sensor cable.

### Sensor Cable Length

The sensor cable comes in 50-foot increments, starting at 50ft. Order the cable longer than you need it. The sensor cable should be cut to fit. Be sure to leave enough slack (1 ½ times the length of the longest rod) in the sensor cable in the event the sensor needs to be removed for maintenance or inspection. If a sensor cable splice is necessary, contact Waterline Controls to order a splice box enclosure.

- Install the sensor cable in earth grounded metal conduit separate from the earth grounded metal electrical conduit housing high voltage lines. In those cases where running separate conduit is not plausible then follow the rules for high and low voltage circuits. Do NOT zip tie the sensor cable to conduit carrying high voltage lines.

### Control Panel

- Provide a dedicated 15 to 20-Amp circuit to the control panel. Do NOT share the ground or neutral with other circuits and by no means should the circuit for a VFD be used.
- We recommend placing the control panel as close to the cooling tower as possible keeping it above the water basin and out of sight of any Variable Frequency Drives (VFD).
- The control panel should be mounted in a convenient location where water spray will not impinge upon the unit and at a height above the tank overflow level to prevent water from feeding into the sensor wire conduit.
- Plan to mount the control panel where the low voltage wire crosses (perpendicularly) the least number of high voltage circuits.

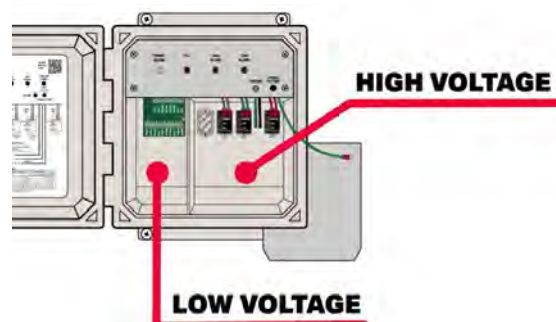

# Electronic Water Level Management Systems

## 5 Year Limited Warranty - *WaterLine* Controls®

The 5 Year Limited Warranty is extended to the original consumer purchaser of this *WaterLine* Controls manufactured by *WaterLine* Controls, Scottsdale, Arizona. *WaterLine* Controls warrants the unit, including the parts and components thereof, to be free of defects in material and workmanship under normal use and service conditions. This warranty does not cover plumbing or normal replacement items and parts, including gaskets and O-rings. *WaterLine* Controls does not cover improper installation of the unit or its parts. If you have any questions regarding the installation of your *WaterLine* Controls unit, please feel free to contact us. Be sure to include the serial number of your unit.

The 5 Year Limited Warranty commences on the date of installation. Parts discovered to have manufacturing defects within 1 Year of installation shall be replaced at no charge to the original consumer. Defects discovered after one year and up to the fifth year following the installation, shall be replaced at a fee of \$275.00 per item. *WaterLine* Controls will repair or replace, at its option, a unit or part proved to be defective within the warranty period and under the conditions of this 5 Year Limited Warranty.

This 5 Year Limited Warranty does not apply if the failure is caused or contributed by any of the following: power failure or reduction of power supplied to the unit, unusual atmospheric conditions, improper handling, improper storage, winter freezing, abuse, improper installation, unsuitable application, lack of reasonable and necessary maintenance, natural disasters, or repairs/alterations made or attempted by other than *WaterLine* Controls or an Authorized Technician approved by *WaterLine* Controls.

The consumer must deliver or ship the unit or warranty parts freight prepaid to *WaterLine* Controls. Authorization to return an item to *WaterLine* Controls must be obtained from *WaterLine* Controls Customer Service Department at 888-905-1892. For further assistance with this process please contact the Customer Service Department. Be sure you insure your shipment against loss or damage in transit.

*WaterLine* Controls is not responsible for the cost of removal of the unit or parts of the unit, damages due to removal, or any other expenses incurred in shipping the unit or parts to or from *WaterLine* Controls or its closest Authorized Service Center or the installation of the repaired or replaced unit. The consumer must bear these expenses.

THIS 5 YEAR LIMITED WARRANTY IS IN LIEU OF ALL OTHER WARRANTIES, EXPRESSED OR IMPLIED, INCLUDING THE IMPLIED WARRANTIES OF MERCHANTABILITY AND FITNESS FOR A PARTICULAR PURPOSE AND ALL SUCH OTHER WARRANTIES ARE DISCLAIMED EXCEPT TO THE EXTENT ANY IMPLIED WARRANTY MAY BE IMPOSED BY STATE CONSUMER LAW. ANY SUCH IMPLIED WARRANTY IMPOSED BY STATE CONSUMER LAW IS LIMITED IN DURATION TO ONE (1) YEAR FROM THE DATE OF INSTALLATION. IN NO EVENT SHALL *WATERLINE* CONTROLS BE LIABLE FOR INCIDENTAL OR CONSEQUENTIAL DAMAGES OR ANY NATURE OR KIND OR FOR DAMAGES TO PERSONS OR PROPERTY, INCLUDING ANY DAMAGE RESULTING FROM THE USE OF THE UNIT WITH A SUBSTANDARD WATER CIRCULATION OR SUPPLY SYSTEM.

Some states do not allow limitations on how long an implied warranty lasts, or the exclusion or limitation of incidental or consequential damages, so the above limitations may not apply to you.

This limited warranty is valid only in the United States of America and Canada.

*WaterLine* Controls • PO Box 12544 Scottsdale • Arizona 85260

Phone: 888-905-1892      Email: [info@waterlinecontrols.com](mailto:info@waterlinecontrols.com)

© SDI 2023