



FPT-35T-110VAC SUBMITTAL

TEMPERATURE ALARM WITH HEATER CONTROL

FIRE PROTECTION TANK CONTROL W/ ALARMS

FUNCTIONAL DIAGRAMS

STATUS INDICATORS (LED)

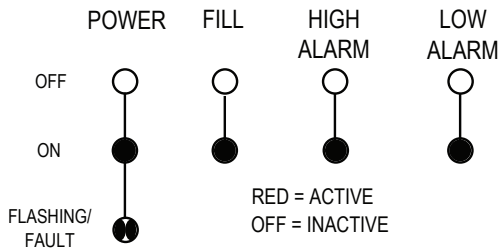

The Power LED will be off on power loss, Green when powered on and Flashing on Fault conditions.

The Status Indicator LEDs will be Red when active and off when inactive.

LOW VOLTAGE DRY CONTACTS TO BUILDING AUTOMATION

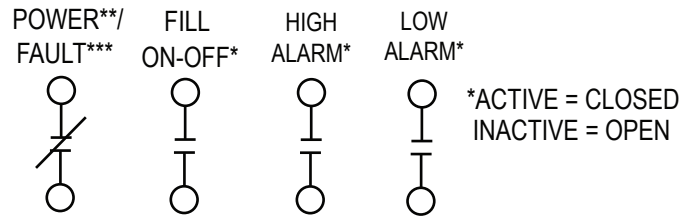

EACH DRY CONTACT IS RELAY (FORM A)
SPST RATED MAX. 60V @ 0.5A

**POWER = OPEN
**POWER LOSS =
CLOSED
***FAULT = ON/ OFF
CYCLE

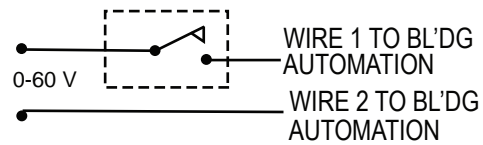

LOW VOLTAGE RELAYS (FORM A) SPST
RATED MAX. 60V @ 0.5A

HIGH VOLTAGE POWER RELAYS

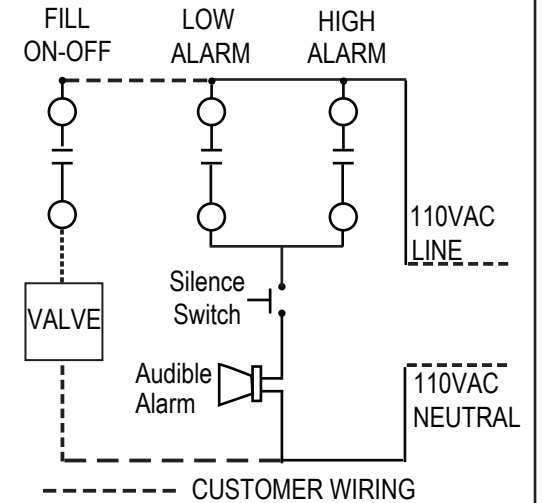

FPT-35T-110VAC SUBMITTAL

TEMPERATURE ALARM WITH HEATER CONTROL

FIRE PROTECTION TANK CONTROL W/ ALARMS

LOW VOLTAGE DRY CONTACTS TO BUILDING AUTOMATION or Fire Panel
RATED MAX. 60V @ 0.5A

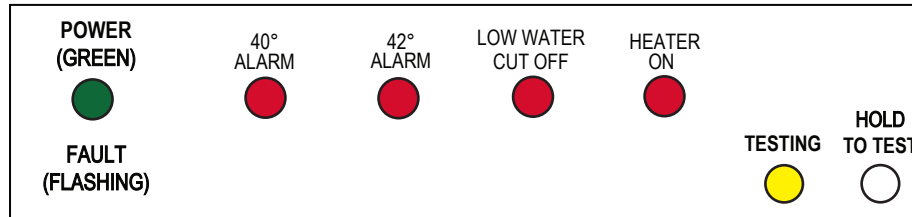
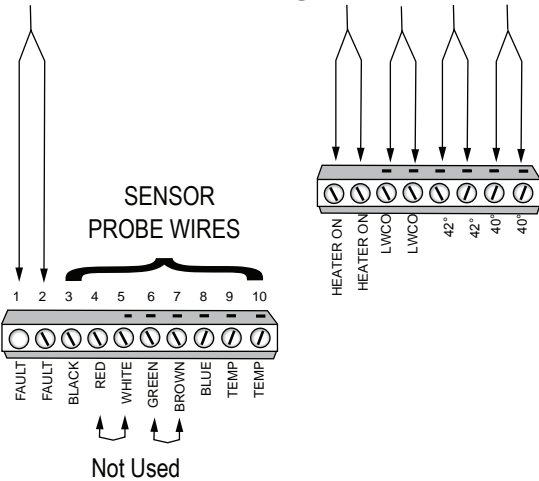

CONTROL UNIT RATINGS	
VOLTS:	110 VAC (50/60 HZ)
AMPS:	0.5 AMPS
WATTS:	55W

HIGH VOLTAGE POWER RELAYS

Form C - SPDT
 Rated max.: 120 VAC @ 40A
 All relays are typical
 All relay terminals are 1/4" male spade

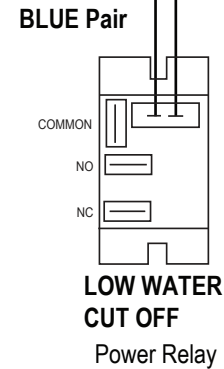

PRODUCT FUNCTION TRUTH TABLE

MODEL	BMS DRY CONTACTS							POWER RELAY				SELF TEST
	FAULT	POWER LOSS	LOW WATER CUTOFF	40° ALARM	42° ALARM	HEATER ON	BAS WIRES	HEATER	LOW ALARM	HIGH ALARM	FILL	
FPT-35		X	X	X	X	X	10	X				

Waterline Controls
 P.O. Box 12544 Scottsdale, Arizona 85260
 Toll Free: 888-905-1892
 Email: info@waterlinecontrols.com
www.waterlinecontrols.com

FPT-35T-110VAC SUBMITTAL

TEMPERATURE ALARM WITH HEATER CONTROL

FIRE PROTECTION TANK CONTROL W/ ALARMS

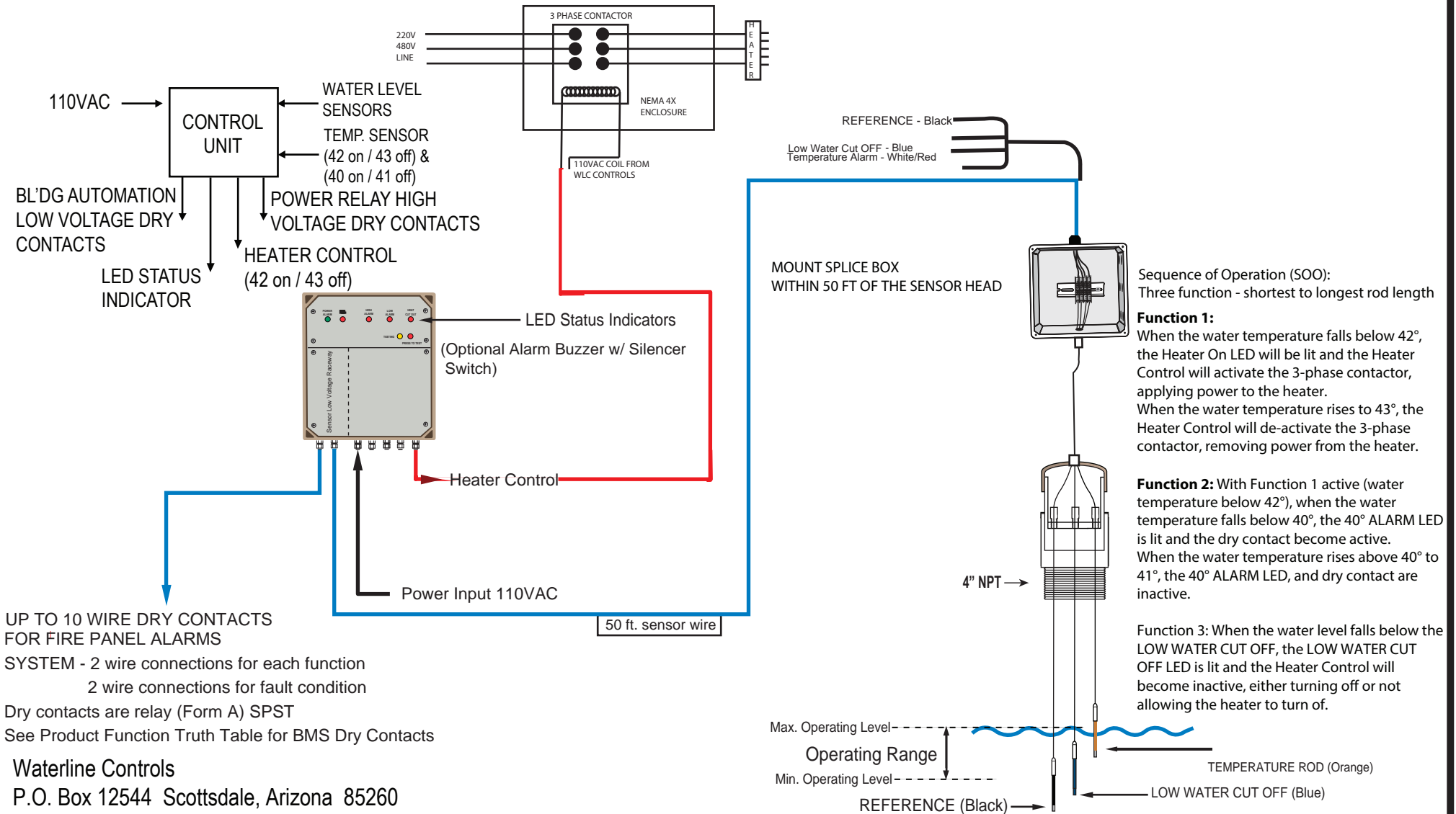

UP TO 10 WIRE DRY CONTACTS FOR FIRE PANEL ALARMS
 SYSTEM - 2 wire connections for each function
 2 wire connections for fault condition
 Dry contacts are relay (Form A) SPST
 See Product Function Truth Table for BMS Dry Contacts

Waterline Controls
 P.O. Box 12544 Scottsdale, Arizona 85260
 Toll Free: 888-905-1892
 Email: info@waterlinecontrols.com
www.waterlinecontrols.com

Electronic Water Level Management Systems

5 Year Limited Warranty - *WaterLine* Controls®

The 5 Year Limited Warranty is extended to the original consumer purchaser of this *WaterLine* Controls manufactured by *WaterLine* Controls, Scottsdale, Arizona. *WaterLine* Controls warrants the unit, including the parts and components thereof, to be free of defects in material and workmanship under normal use and service conditions. This warranty does not cover plumbing or normal replacement items and parts, including gaskets and O-rings. *WaterLine* Controls does not cover improper installation of the unit or its parts. If you have any questions regarding the installation of your *WaterLine* Controls unit, please feel free to contact us. Be sure to include the serial number of your unit.

The 5 Year Limited Warranty commences on the date of installation. Parts discovered to have manufacturing defects within 1 Year of installation shall be replaced at no charge to the original consumer. Defects discovered after one year and up to the fifth year following the installation, shall be replaced at a fee of \$275.00 per item. *WaterLine* Controls will repair or replace, at its option, a unit or part proved to be defective within the warranty period and under the conditions of this 5 Year Limited Warranty.

This 5 Year Limited Warranty does not apply if the failure is caused or contributed by any of the following: power failure or reduction of power supplied to the unit, unusual atmospheric conditions, improper handling, improper storage, winter freezing, abuse, improper installation, unsuitable application, lack of reasonable and necessary maintenance, natural disasters, or repairs/alterations made or attempted by other than *WaterLine* Controls or an Authorized Technician approved by *WaterLine* Controls.

The consumer must deliver or ship the unit or warranty parts freight prepaid to *WaterLine* Controls. Authorization to return an item to *WaterLine* Controls must be obtained from *WaterLine* Controls Customer Service Department at 888-905-1892. For further assistance with this process please contact the Customer Service Department. Be sure you insure your shipment against loss or damage in transit.

WaterLine Controls is not responsible for the cost of removal of the unit or parts of the unit, damages due to removal, or any other expenses incurred in shipping the unit or parts to or from *WaterLine* Controls or its closest Authorized Service Center or the installation of the repaired or replaced unit. The consumer must bear these expenses.

THIS 5 YEAR LIMITED WARRANTY IS IN LIEU OF ALL OTHER WARRANTIES, EXPRESSED OR IMPLIED, INCLUDING THE IMPLIED WARRANTIES OF MERCHANTABILITY AND FITNESS FOR A PARTICULAR PURPOSE AND ALL SUCH OTHER WARRANTIES ARE DISCLAIMED EXCEPT TO THE EXTENT ANY IMPLIED WARRANTY MAY BE IMPOSED BY STATE CONSUMER LAW. ANY SUCH IMPLIED WARRANTY IMPOSED BY STATE CONSUMER LAW IS LIMITED IN DURATION TO ONE (1) YEAR FROM THE DATE OF INSTALLATION. IN NO EVENT SHALL *WATERLINE* CONTROLS BE LIABLE FOR INCIDENTAL OR CONSEQUENTIAL DAMAGES OR ANY NATURE OR KIND OR FOR DAMAGES TO PERSONS OR PROPERTY, INCLUDING ANY DAMAGE RESULTING FROM THE USE OF THE UNIT WITH A SUBSTANDARD WATER CIRCULATION OR SUPPLY SYSTEM.

Some states do not allow limitations on how long an implied warranty lasts, or the exclusion or limitation of incidental or consequential damages, so the above limitations may not apply to you.

This limited warranty is valid only in the United States of America and Canada.

WaterLine Controls • PO Box 12544 Scottsdale • Arizona 85260

Phone: 888-905-1892 Email: info@waterlinecontrols.com

© SDI 2022