

Electronic Water Level Management Systems



INSTALLATION INSTRUCTIONS Model FPT 40



WATERLINE CONTROLS is the optimum choice for any situation requiring precise control of a water level. It is ideal for automatically maintaining the correct water level in cooling towers, storage tanks, or process water applications.

WATERLINE CONTROLS FPT 40 models achieve control and maintain correct water levels using electronics and a microprocessor to provide signals that open/close valves and remotely signal Fire Panel and/or other control/recording devices.

WATERLINE CONTROLS uses corrosion/plating resistant sensor probes that are not prone to degradation.

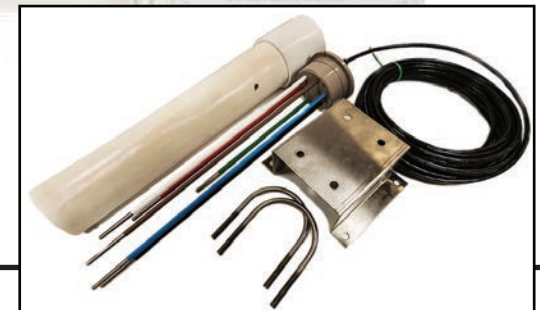

IMPORTANT SAFETY INSTRUCTIONS

1. Call the factory with any questions. 1-888-905-1892 or write to: System Dynamics, P.O. BOX 12544, Scottsdale, AZ 85260
2. Read and follow all instructions.
3. Disconnect all power before opening the internal cover/s or making any connections to the unit.
4. Do not install in locations where sprinklers or other watering devices will allow water to impinge on the unit.
5. Sensor wires must be continuous and not spliced. Call factory if there is a need to be spliced.
6. Make sure the unit is connected properly to earth ground.
7. Only qualified personnel should install this unit or replace the "replaceable" parts.
8. Only factory supplied parts should be used whenever a replaceable part is needed.
9. The manufacture will not be liable for any injury or damage that may arise from the misuse of this unit or from failure to follow all of these instructions.
10. Save these instructions and provide them to the end user.
11. This unit shall not be used in any "safety critical" application or where the failure of any function or component may cause death or personal injury.
11. Ne pas utiliser cet élément quand les blessures ou la mort peuvent les présenter.
12. Use copper (CU) wire only for all connections.

Electronic Water Level Management Systems

The Waterline Controls panel is NEMA 4X rated for indoor or outdoor installation. The panel is powered by 110 VAC.

The power relay(s) included are switched by the microprocessor and may be used to control valves or solenoids directly (120 VAC @ 40A max.) The power relays can also be used as pilot relays to contactors for larger devices such as motors or three-phase circuits.

A low voltage dry contact set is provided for each output function of the model. Included in all models is a dry contact set for the fault condition (defined in next paragraph). The dry contacts are (FORM A) SPST relays rated 60 VAC/DC @ 0.5 A. These are used for remote monitoring and indication to Fire Panel and/or other remote recording devices.

The power "on" indicator for the unit is a solid green POWER/ALARM LED. Upon "fault" condition the POWER/ALARM LED will either flash red at one second intervals or display red continuously, indicating a system alarm. The POWER/ALARM LED will flash red when the microprocessor detects out of sequence submersion of the water level sensor. The POWER/ALARM LED will light red continuously for one minute, then reset, when the "Fill" relay has been continuously switched "on" for 6 hours. The other LEDs along the top of the unit correspond to each output function of the model. These LED are lit solid when the relay contacts are closed and remain lit until the water level changes. Upon change in the water level, the microprocessor provides the necessary control changes to the power relay(s).

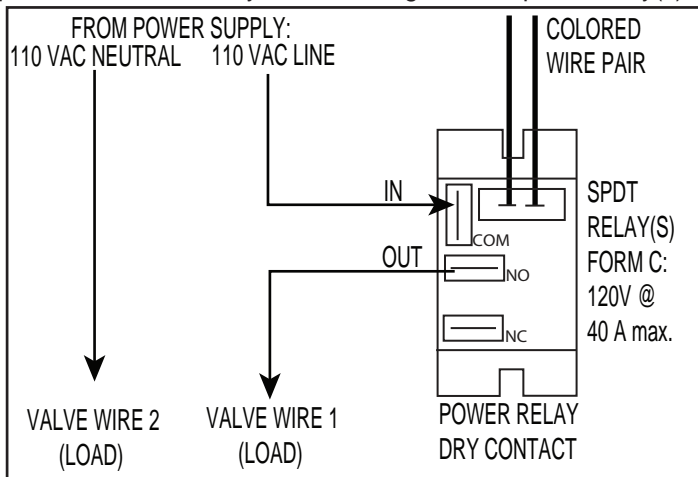

NOTE: FPT 40 power relays are both pre-wired to audible alarm from factory

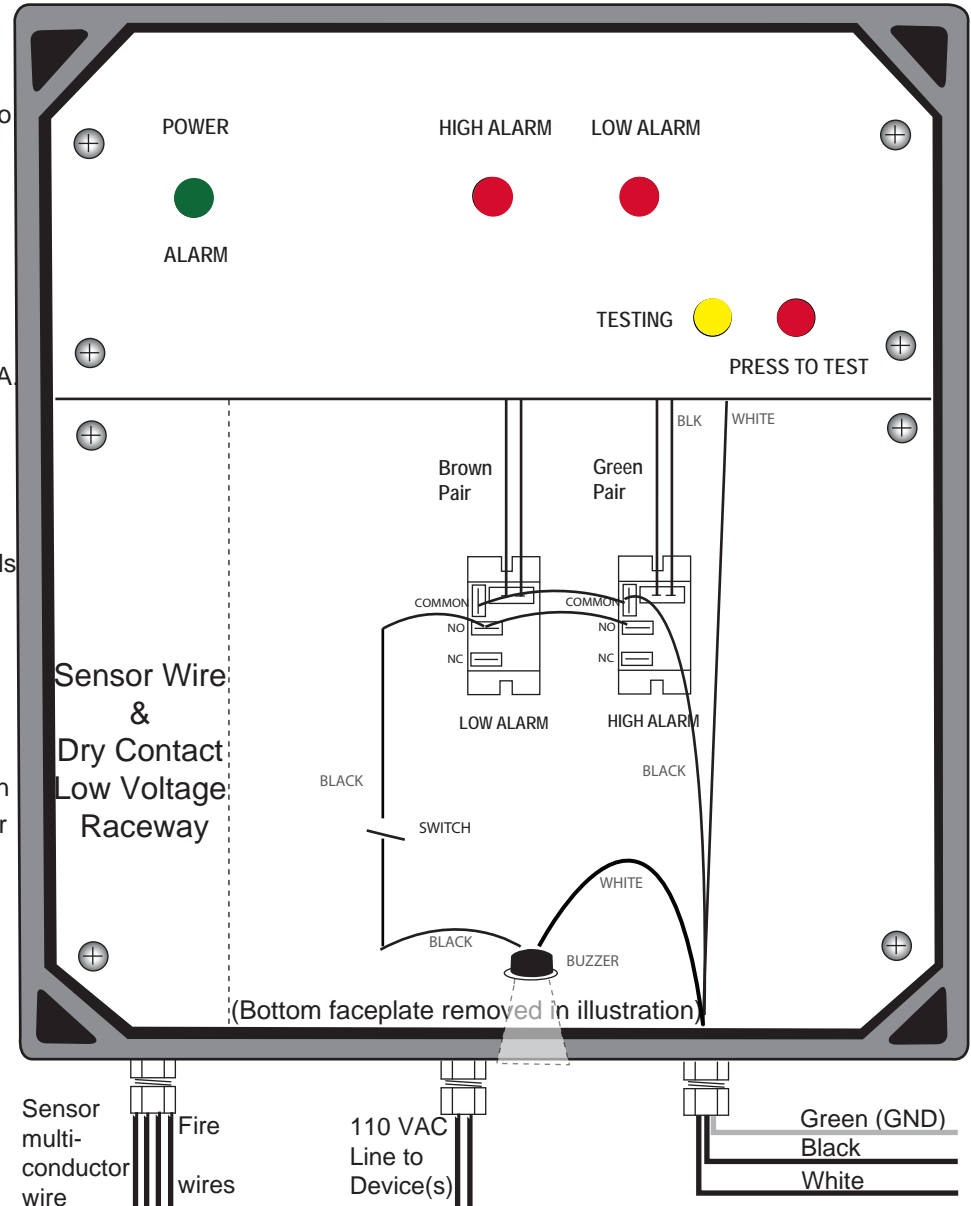

*Use separate earth grounded metal electrical conduit to house low-voltage sensor wires and high-voltage wires.

Electronic Water Level Management Systems

SENSOR ASSEMBLY INSTALLATION

The Waterline Controls FPT 40 control panel should be mounted in a convenient location where water spray will not impinge upon the unit and at a height above the tank overflow level to prevent water from feeding in to the sensor wire conduit. The unit and the input/output cabling must be securely attached to the mounting surface.

Secure the probe assembly to a suitable mounting surface using one of the sensor mounting options (Pg.5). Be careful to ensure that the top portion of the assembly is not in contact with the water. The sensor probe assembly is supplied with a multi-conductor sensor cable pre-attached.

Route the cable along an appropriate location and determine if the length needs to be shortened. Consult "Installation Cautions" on page 4 before routing sensor cable and finalizing installation strategy. The cable may be cut to a shorter length but must not be spliced in order to increase the length other than using Waterline Controls splice enclosures (SPLICE KIT).

Run sensor wire in earth grounded conduit to control panel. Use separate earth grounded metal electrical conduit to house low voltage and high voltage wires. The high voltage device control output wires are connected to the NO terminal of its function corresponding power relay using (1/4 inch spade) connector supplied by the installer. **NOTE:** The function of each power relay is color coded by the wires powering the coil of the relay (see page 2). The power rating on the relay should not be exceeded by the device it powers. If the depth of the probes need to be seen while the sensor assembly is installed, mark the sensor probe levels on the outside of the pipe or tank with a permanent marker.

Sequence of Operation (SOO): Two function - shortest to longest rod length

1) When water level contacts GREEN rod, HIGH ALARM LED status indicator, dry contact, and power relay are active. When water level falls below GREEN rod, HIGH ALARM LED status indicator, dry contact, and power relay are inactive.

2) When water level contacts BROWN rod, LOW ALARM LED status indicator, dry contact, and power relay are active. When water level falls below BROWN rod, LOW ALARM LED status indicator, dry contact, and power relay are active.

Figure 2 (Sensor illustration for FPT 40)

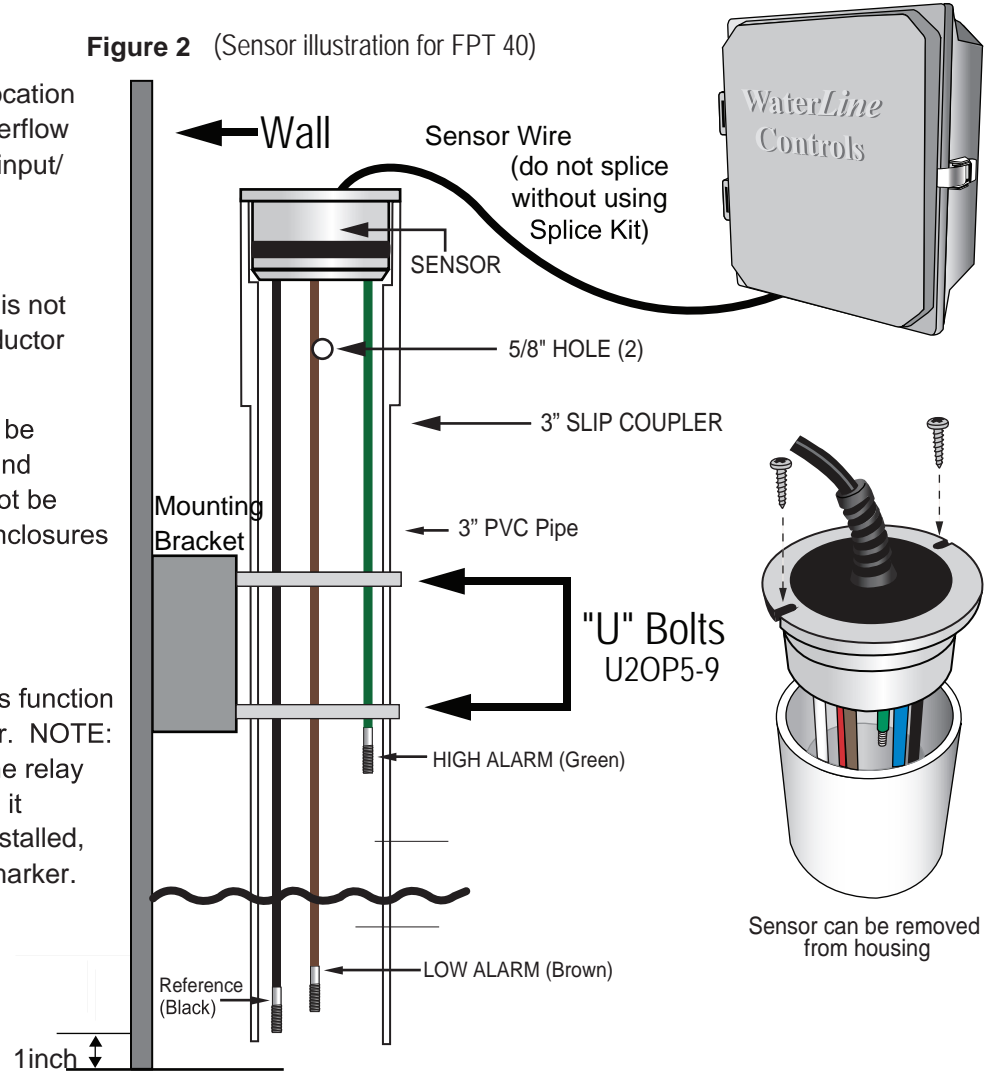

WIRE COLOR & COLOR OF PROBES CORRESPOND

PROBE LAYOUT (FPT 50)

PROBE WIRE SHIELD - Connect to Black sensor wire input (ground)

Color	Function	Length
Black	Ground	17"
Brown	LA	17"
Green	HA	10 3/8"

NOTE: Number/ color/ function/ length of probes differ by model

Electronic Water Level Management Systems

TEST INSTRUCTIONS

To initiate the test,

1. Press the "PRESS TO TEST" push button momentarily. The yellow LED will light and remain on until the "test function" is complete.
2. The controller automatically sequences through the functions and concludes with three red flashes of the Power/Alarm LED.

NOTE: This test will take approximately 2 minutes and cannot be interrupted. It is intended to test the function of the dry contacts and power relays with devices connected.



Troubleshooting Guide

PARTS SUPPLIED

- 1 - Waterline Controls® Panel
- 1 - Stainless steel probe assembly w/ 50 ft. multi-conductor wire
- 1 - Mounting kit
- 3 - Power relays (Number of relays is a function of model)

REPLACABLE PART NUMBERS

- Control Panel.....FPT 40
- Power Supply.....PS-110
- Sensor (3" Plug).....Sensor 3050
- Power relay.....PG8P

DEFINITIONS

LOW ALARM: The water level is approaching the unsafe level.

FILL: Make up "on".
The system is calling for water to be added.

HIGH ALARM: The water level is approaching the maximum allowable level of the environment.

DRY-CONTACTS

The dry contact sets included in the Waterline Controls panel can be used as an aid to remotely signal the Fire Panel of the current status of the controller's output functions. There is a dry contact set corresponding to each controller output function. The dry contact changes from an open circuit to a closed circuit when the power relay is activated. (e.g. FPT 40 functions: LOW ALARM, HIGH ALARM). Other Waterline Controls FPT models may have a different number of dry contacts.

The dry contacts are rated at 60 VAC/DC @ 0.5 Amps. A fault dry contact set is present on all models. This can be used as an aid to remotely signal the operator when 1) the system has lost power, or 2) microprocessor detects out of sequence of submersion of the water level sensor.

INSTALLATION CAUTIONS

VFDs: The output of variable-frequency drives (VFDs) produce large, rapid voltage swings - generating significant electrical noise, or electromagnetic interference*. It is required to maintain as much distance as possible from VFD panels, wires, and devices when installing the Waterline Controls panel, sensor probe, and sensor probe cable in order to ensure proper function of the system - At least 15 feet from VFD panels, wires, and devices or behind an earth grounded metal barrier (e.g. earth grounded stainless steel cooling tower). Sensor wires should be housed in earth grounded metal electrical conduit separate from the earth grounded metal electrical conduit housing high voltage wires.

Sensor Wire: Coiling excess wire from the sensor can gather ambient electronic noise like an antenna. It is recommended to use as short of a sensor wire as possible, leaving only enough excess wire to be able to remove the sensor from the housing should service be needed. It is also recommended to NOT run the sensor wire parallel to VFD control wires, ensuring electromagnetic interference is not picked up from the control wires. It is okay to cross these wires perpendicularly.

* Information from article: Frank J. Bartos, P.E., Control Engineering 12/01/2009 , "Electromagnetic Interference: What Drive Users Need to Know"

LOW VOLTAGE RACEWAY

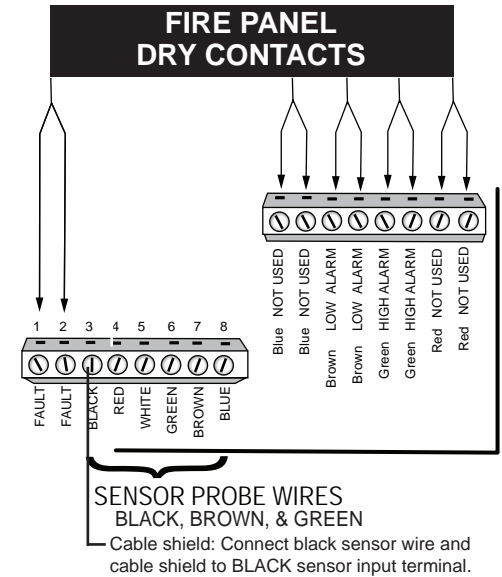

Example Electrical Illustration:
Green - HIGH ALARM dry-contact wire pair

Active dry-contact = closed switch

Inactive dry-contact = open switch

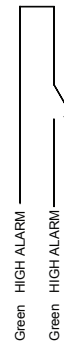

SENSOR MOUNTING OPTIONS

A WALL MOUNT

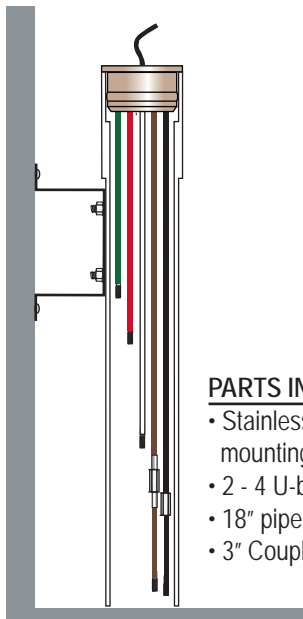

PARTS INCLUDED

- Stainless steel mounting bracket
- 2 - 4 U-bolts
- 18" pipe
- 3" Coupler

SIDE WALL MOUNT

B EXTERIOR MOUNT

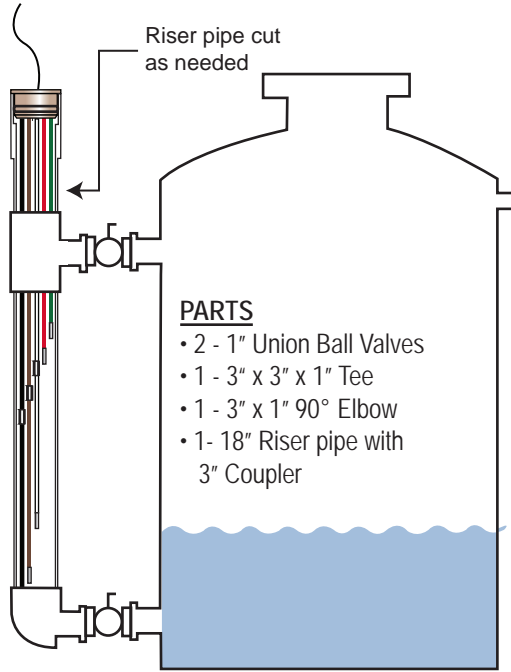

PARTS

- 2 - 1" Union Ball Valves
- 1 - 3" x 3" x 1" Tee
- 1 - 3" x 1" 90° Elbow
- 1 - 18" Riser pipe with 3" Coupler

C INSIDE TANK-BULKHEAD FITTING

PARTS

- 3" Bulkhead
- 2 - 3" SLpx NPT Coupler

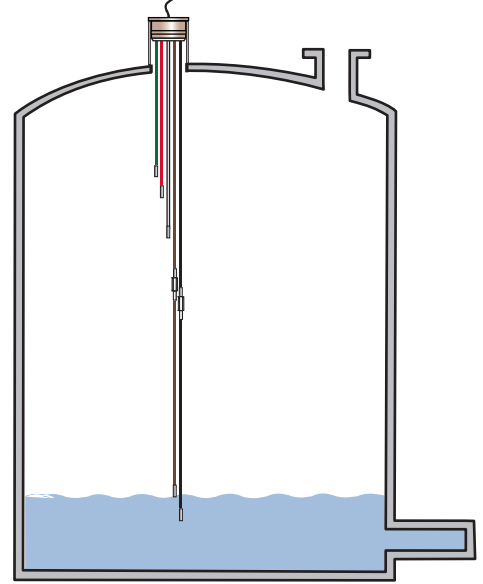

D FLANGE

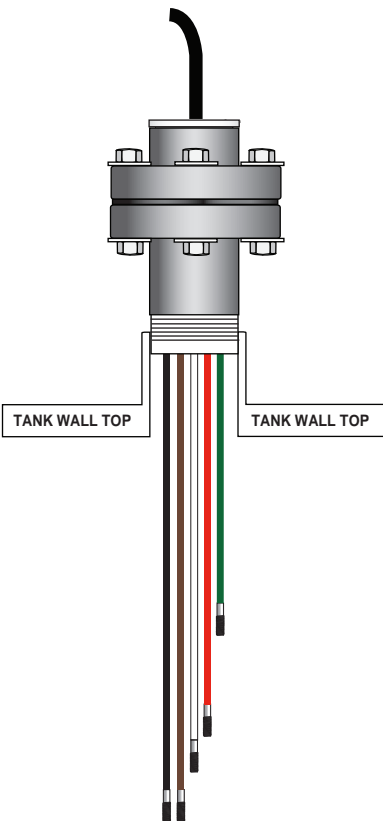

E TOP OF TANK ADJUSTABLE MOUNTING SLEEVE FOR 4"

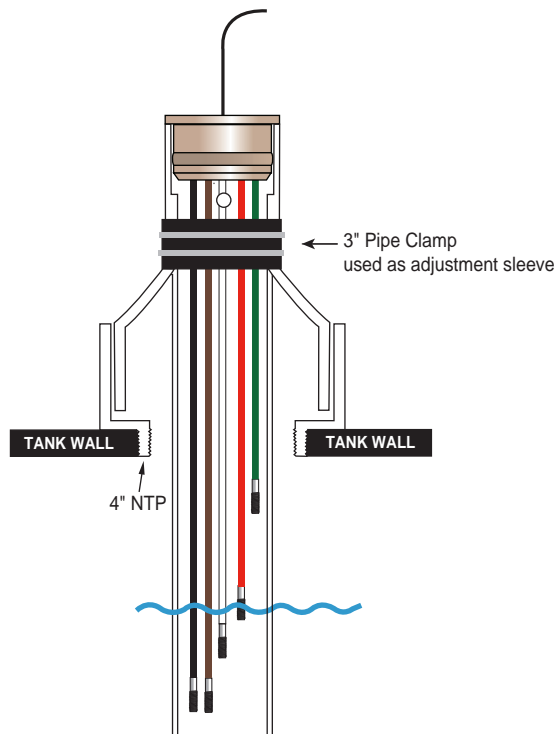

SENSOR EXTENSION ROD INSTALLATION

ILLUSTRATION:

Rods "D" and "E" have been extended.

Rods "A", "B", and "C" haven't been extended.

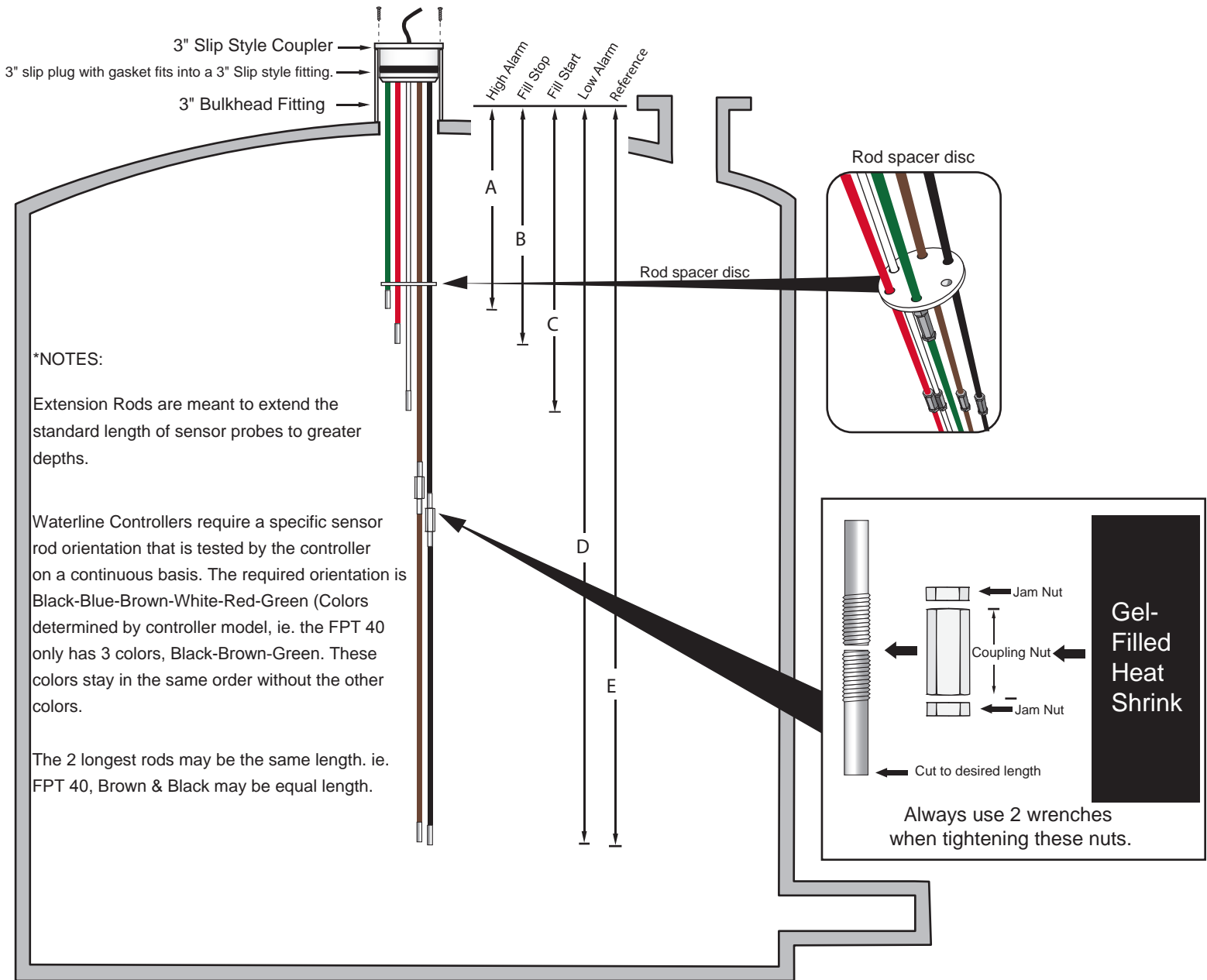

*NOTES:

Extension Rods are meant to extend the standard length of sensor probes to greater depths.

Waterline Controllers require a specific sensor rod orientation that is tested by the controller on a continuous basis. The required orientation is Black-Blue-Brown-White-Red-Green (Colors determined by controller model, ie. the FPT 40 only has 3 colors, Black-Brown-Green. These colors stay in the same order without the other colors.

The 2 longest rods may be the same length. ie. FPT 40, Brown & Black may be equal length.

- 1) Cut extension rods to desired lengths* (See NOTES above) & trim colored jacketing to expose rod tips 1-2"
- 2) Slide rod spacer disc on through all sensor rods, above all threads
- 3) Thread jam nut all the way onto threaded end of each sensor rod desired to be extended
- 4) Thread Coupling nut half way onto threaded end of each sensor rod
- 5) Thread jam nut all the way onto threaded end of each extension rod being used
- 6) Slide gel-filled heat shrink onto extension rod, past the jam nut
- 7) Thread each extension rod into the coupling nut that is extending beyond its color corresponding sensor rod
- 8) Ensure extended rod lengths meet the length differential requirements* (See NOTES above)
- 9) Tighten jam nuts on each sensor rod using two wrenches, ensuring the coupling nut is bound by the two jam nuts
- 10) Slide gel-filled heat shrink above the coupling nut & jam nuts & tighten/shrink with heat gun

Waterline Controls®	
P.O. Box 12544 Scottsdale, Arizona 85260	
Toll Free: 888-905-1892 Fax: 480-629-8223	
TITLE: Tank Installation for Sensors over 17"	
WATERLINE CONTROLS®	DWN BY Pamela Peterson APPVD BY Bill Seneff
SCALE: NTS	DWG NO.
DATE: 4-2-18	EXT ROD INSTALLATION