

## SENSOR APPROVAL SHEET

CUSTOMER
PO#
SO#
SHIP DATE
QUANTITY
WIRE LENGTH (Ft.)

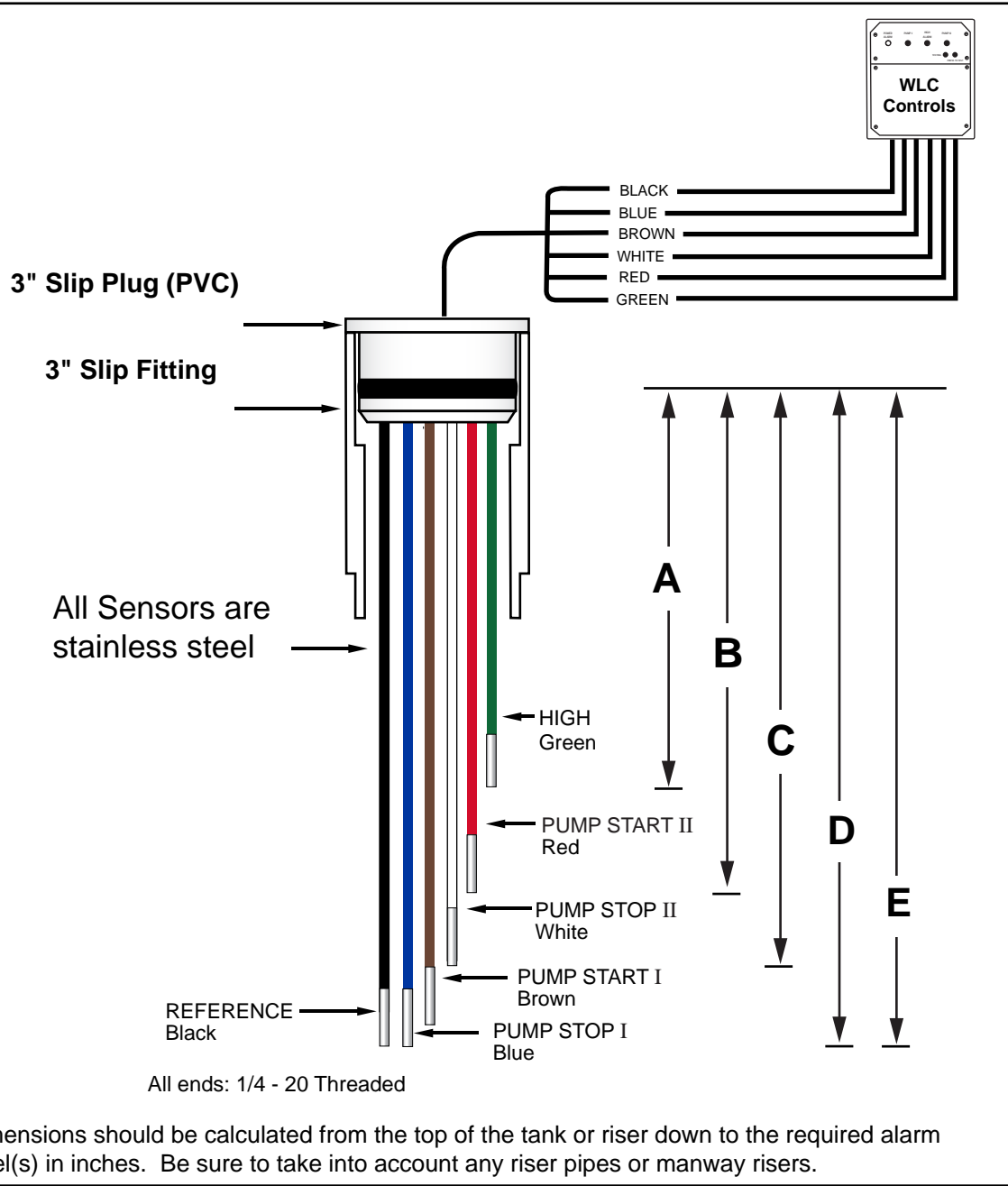

Waterline Controls  
P.O. Box 12544  
Scottsdale, Arizona 85260  
Toll Free: 888-905-1892  
info@waterlinecontrols.com  
www.waterlinecontrols.com

SENSOR		STANDARD LENGTHS	
Green	High	A	10 3/8"
Red	Pump Start II	B	14"
White	Pump Stop II	C	14 7/8"
Brown	Pump Start I	D	16 3/8"
Blue	Pump Stop I	E	17"
Black	Reference	Same length as longest rod	

Name: \_\_\_\_\_

Company: \_\_\_\_\_

Signature: \_\_\_\_\_

Date: \_\_\_\_\_

### SENSOR APPROVAL SHEET

CUSTOMER
PO#
SO#
SHIP DATE
QUANTITY
WIRE LENGTH (Ft.)

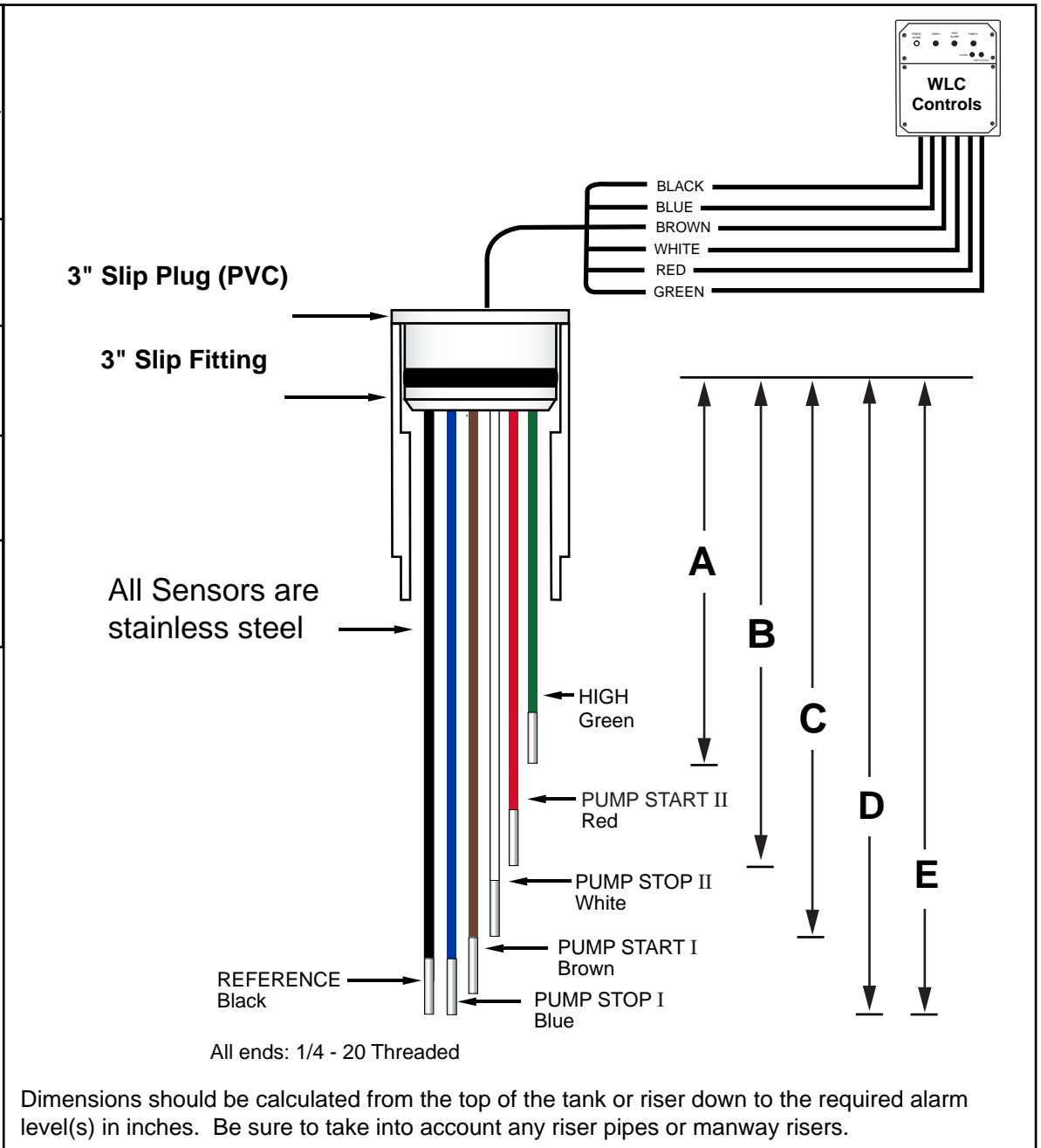

Waterline Controls  
P.O. Box 12544  
Scottsdale, Arizona 85260  
Toll Free: 888-905-1892  
info@waterlinecontrols.com  
www.waterlinecontrols.com

SENSOR		LENGTHS	
Green	High	A	
Red	Pump Start II	B	
White	Pump Stop II	C	
Brown	Pump Start I	D	
Blue	Pump Stop I	E	
Black	Reference	Same length as longest rod	

Name: \_\_\_\_\_

Company: \_\_\_\_\_

Signature: \_\_\_\_\_

Date: \_\_\_\_\_