



# Fill Models Water Level Controls

## GENERAL INFORMATION:

The WLC Series may look like the competition but the unit is revolutionary in its design. The WLC Series is perfect in any application where water level management is important such as cooling tower basins and water holding tanks for cooling towers. It uses a microprocessor that monitors all probes for correct operation and then provides the corresponding outputs to drive power relays, the Building Automation System and a visual indication of the operational status. The Modular construction and a self-test feature insure user-friendly operation. By using a very low voltage and current, WLC Series sensors never foul or degrade.

So when we say "Never Replace A Water Level Controller Again" we mean it.

## STAND ALONE SYSTEM WITH CONNECTIONS TO BUILDING MANAGEMENT SYSTEM.

## APPLICATIONS

- Cooling Towers, Water Holding Tanks, Commercial Swimming Pools and Fountains, Water Level Controls for Waste Water Treatment Plant Systems.
- Designed for both initial installation and replacement of any brand.
- Large Cooling Tower Basins or Sumps using extension Rod Kits, 45.5" each, cut to any depth.
- External static pipe (optional).
- Direct replacements, function for function, for BAC\* towers, EVAPCO\* towers and Marley Towers\*.
- Software customized for special situations.

\* BAC is a registered trademark of Baltimore Aircoil Company. EVAPCO is a registered trademark of Evapco, Inc. Marley is a registered trademark of SPX Corporation.

**NEVER REPLACE AN  
ELECTRONIC LEVEL CONTROLLER  
OR FLOAT AGAIN!**

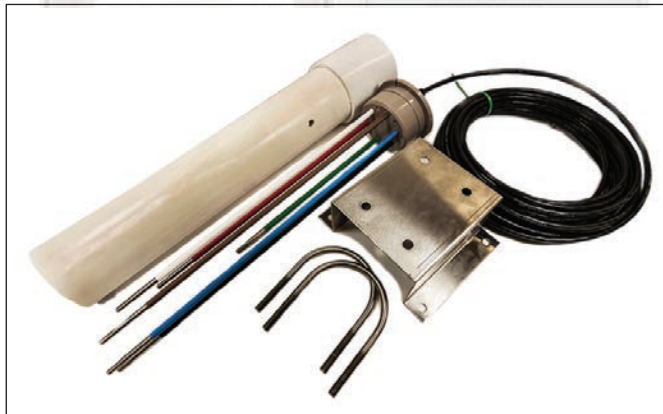

STANDARD KIT

## COMMUNICATION WITH BUILDING MANAGEMENT

Building Automation dry contacts to tell building operator when:

- Power loss to controls
- Low water
- Heater inactive due to Low-low water level
- Fill cycle ON and OFF
- High water
- Heater active
- Lightning strikes

## FEATURES

- Easy to install.
- Microprocessor controlled.
- Compensates for wave action.
- Easy-to-understand LED display.
- No moving parts or mechanical floats to break or rust.
- Modular Construction
- One-Step Internal Testing system for the electronics.
- Built for easy troubleshooting
- Lifetime Limited Warranty\*

\* See Warranty for details

## PRODUCT SPECIFICATIONS

- Accurately manages levels to within 1/8" of operating range.
- 30VDC, 24VAC or 110/220VAC - 50/60 Hz: specify voltage required when ordering.
- Separate power relay for each function.
- Dry contacts for are rated for .5 amps at 60 volts.
- Sensor wire should not be spliced. Standard Kit has 50 ft. length.
- Sensor wire available in: 50 ft., 100 ft., 150 ft., 200 ft., 250 ft., 300 ft. or longer lengths if needed.

## SENSOR PROBES

We make custom probes to fit any application. All sensor rod tips are threaded so Extension Kits can be added if needed.

### Installations:

- A licensed electrician can install the control box and sensors in less than one hour.
- 110VAC Solenoid required. (We recommend any type of slow closing valve)
- Sensors attach to environment wall or Sensor mounts in an external static pipe or Sensor slips into a 3" female fitting.
- The sensor cable should be installed in a grounded metal conduit in order to prevent spurious signals from interfering with the sensor operation.

## MODELS

**PRODUCT FUNCTION TRUTH TABLE** The Blank spaces below mean "No Connection or Function"

\*All controls have built-in self testing systems.

MODEL	BMS DRY CONTACTS							POWER RELAY				SELF TEST	HEATER CONTROL
	FAULT	POWER LOSS	HEATER CUT OFF	LOW ALARM	HIGH ALARM	FILL	BAS WIRES	HEATER CUT OFF	LOW ALARM	HIGH ALARM	FILL		
WLC3000	X	X				X	4				X	X	
WLC4000	X	X			X	X	6			X	X	X	
WLC4500	X	X		X		X	6		X		X	X	
WLC5000	X	X		X	X	X	8		X	X	X	X	
WLC6000	X	X	X	X	X	X	10	X	X	X	X	X	
WLC6100T	X	X	X	X	X	X	10	X	X	X	X	X	X

Fill Height Only  
 Fill Height with High Level Alarm  
 Fill Height with Low Level Alarm  
 Fill Height with High and Low Level Alarm  
 Fill Height with High and Low Level Alarm and Low Level Cut-off  
 Fill W/ High and Low Alarm with Temperature controls for Basin Heater

# UNIVERSAL DIAGRAM FOR ALL MODELS

## FILL WITH HIGH LEVEL ALARM, LOW LEVEL ALARM, LOW-LOW LEVEL HEAT CUT-OFF & HEATER CONTROL

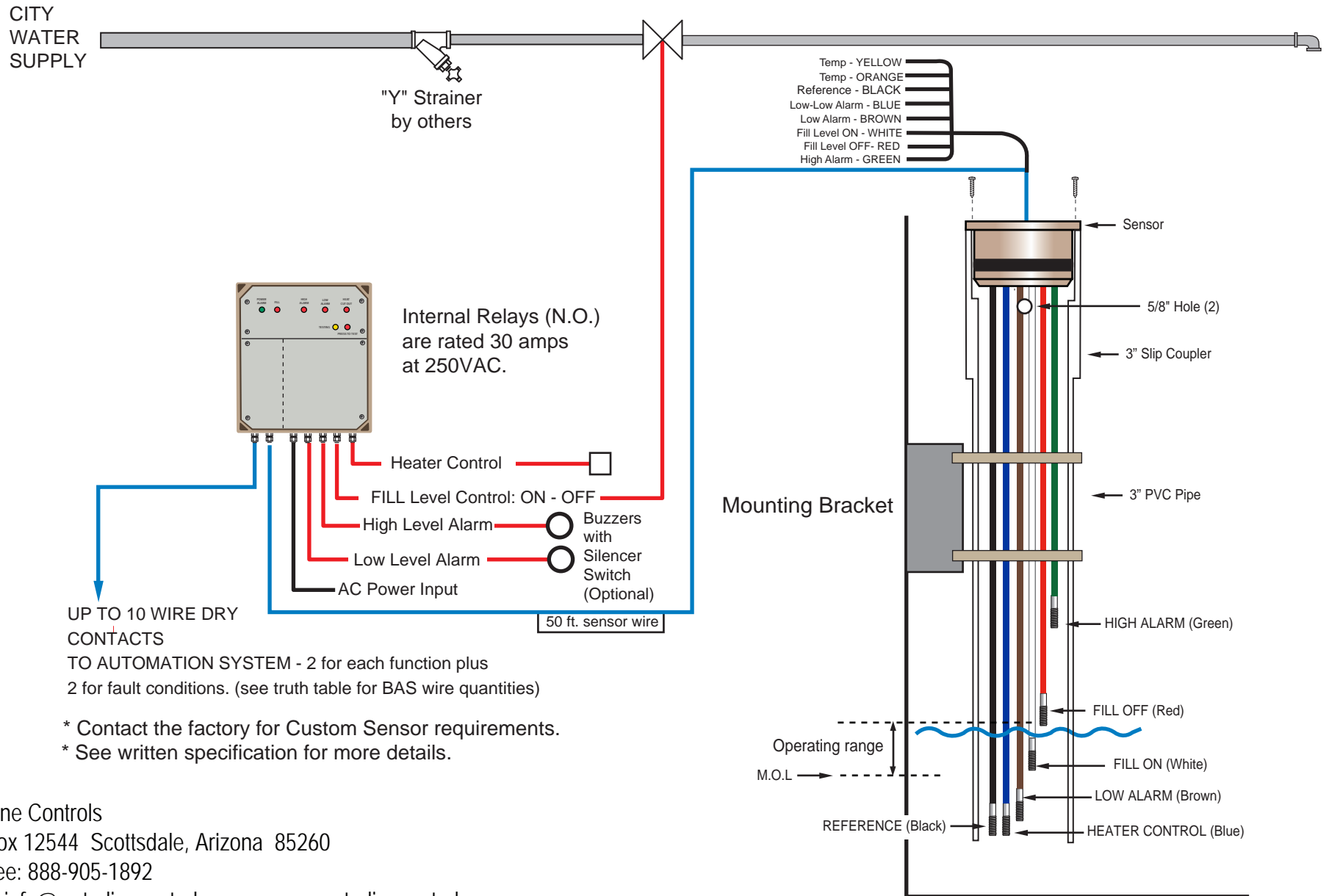

Waterline Controls  
 P.O. Box 12544 Scottsdale, Arizona 85260  
 Toll Free: 888-905-1892  
 Email: [info@waterlinecontrols.com](mailto:info@waterlinecontrols.com) • [www.waterlinecontrols.com](http://www.waterlinecontrols.com)

# OPTIONS

## Audible Alarms

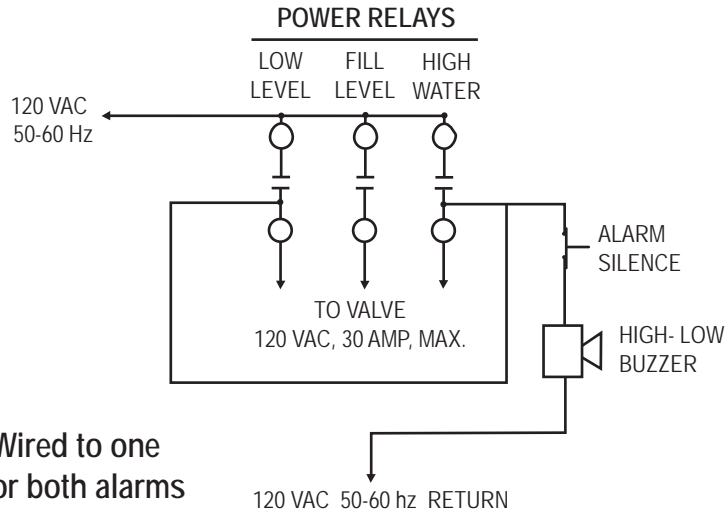

## Dual Probe Sensors

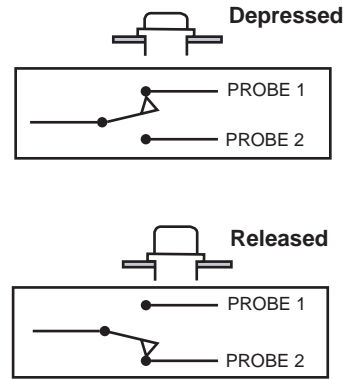

- Push button latching switch.
- The switch is mounted on the Waterline Controls panel so no other components are required.
- The Sensor is intrinsically safe.

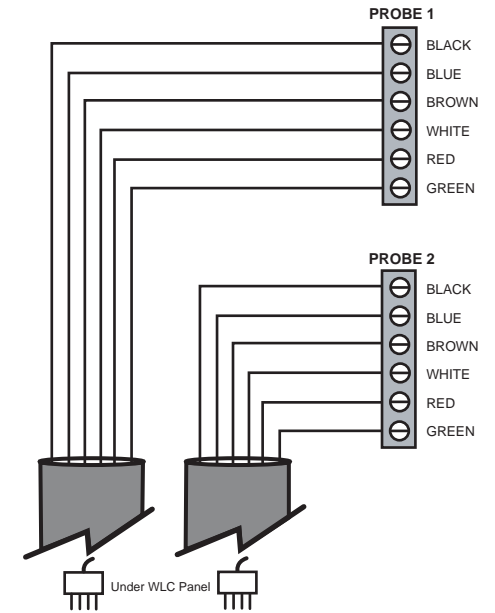

## External Static Pipe

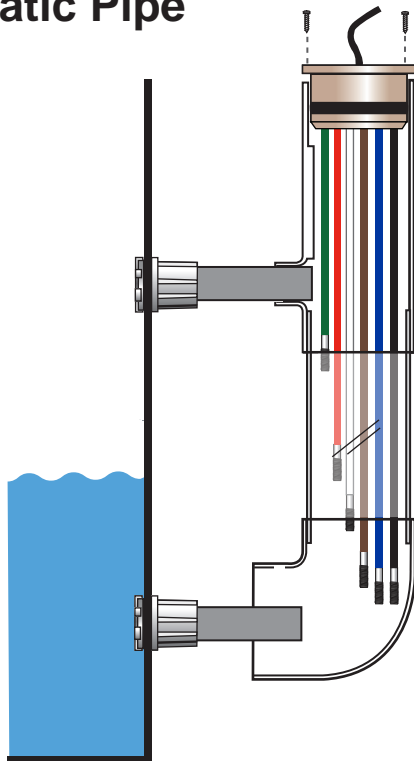

## Tank Installation For Sensors over 17"

