

# Electronic Water Level Management Systems



## INSTALLATION INSTRUCTIONS



### Waterline Controls Model WLC2000 through WLC6000

**Waterline Controls** is the optimum choice for any situation requiring the precise control of a water level. It is ideal for automatically maintaining the correct level in cooling towers, storage tanks, or process water applications.

**Waterline Controls** Models WLC2000 through WLC6000 achieve control by the use of a corrosion resistant probes that sense the water level and then in conjunction with electronics and a microprocessor, provides signals that can be used to open/close valves and other control or recording devices thus maintaining correct levels.



### IMPORTANT SAFETY INSTRUCTIONS

1. Call the factory with any questions. 1-888-905-1892 or write to: System Dynamics, P.O. BOX 12544, Scottsdale, AZ 85260
2. Read and follow all instructions.
3. Disconnect all power before opening the internal cover/s or making any connections to the unit.
4. Do not install in locations where sprinklers or other watering devices will allow water to impinge on the unit.
5. Sensor wires must be continuous and not spliced.
6. Make sure the unit is connected properly to earth ground.
7. Only qualified personnel should install this unit or replace the "replaceable" parts.
8. Only factory supplied parts should be used whenever a replaceable part is needed.
9. The manufacturer will not be liable for any injury or damage that may arise from the misuse of this unit or from failure to follow all of these instructions.
10. Save these instructions and provide them to the end user.
11. This unit shall not be used in any "safety critical" application or where the failure of any function or component may cause death or personal injury.
11. Ne pas utiliser cet élément quand les blessures ou la mort peuvent les présenter.
12. Use copper (CU) wire only for all connections.

Waterline Controls is a registered trademark of SDI.

# Electronic Water Level Management Systems

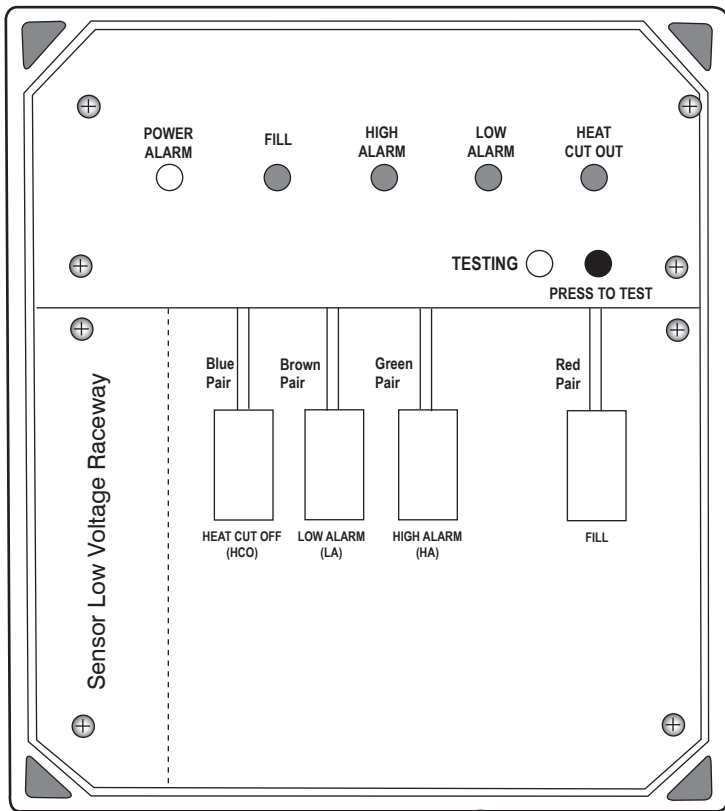

Quantity of relays and lights are a function of the model.

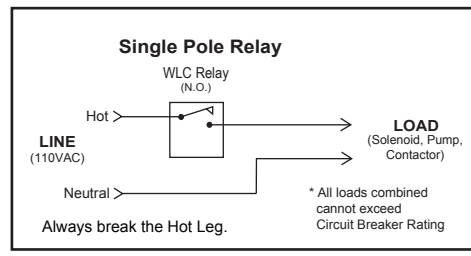

"Bottom plate removed in illustration."

The unit is powered by either 110 VAC or 220 VAC 60 HZ 0.5 Amp. The input voltage is determined by the option selected. If the 110 VAC option is selected, then the input power wires are: one black and one white. If the 220 VAC option is selected, then the two input power wires are both black.

The unit is rated for indoor or outdoor installation.

These power relays may be used to control valves, or solenoids: but not motors. There are also low power SPST relays whose contacts are rated at 50 VAC/DC 0.25 Amp. that can be used as an additional indicator or to provide an indication to an event recorder, computer or automation system.

The normal indicator on the unit is a green LED that is a "power ON" indicator and is on whenever power is applied to the unit. This LED will either flash red (at a 1 second rate) when a sensor wire is shorted to ground or open circuited or show red constantly for one minute when the "Fill" relay has been at Fill command (on continuously) for 6 hours. There are also other LED's that turns ON whenever the relay contacts are closed. These indicate a very low water level condition, or a low water or high water level condition and will remain ON until the level changes to some other level. See Table 1 for the LED functions associated with the various models. The contact with the water is sensed by the electronics and the microprocessor then provides the necessary control for the various outputs.

Figure 1.  
WLC2000 through WLC6000

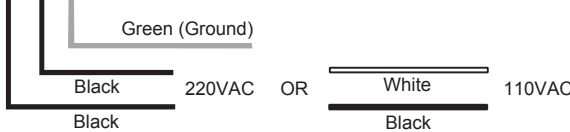

### The "replaceable" parts are:

- Waterline Control CONTROLLER — part # WLC2000 through WLC6000 with option 110 or 220 vac (specify option: 110 or 220 VAC)
- Stainless steel probe assembly — See Sensor assembly appendix.
- Power relay — part # PG8P
- U Bolts/nuts U20P5-9
- Mounting bracket MB2

### The parts supplied are:

- 1- The Waterline Control CONTROLLER.
- 1- Stainless steel probe assembly with 50 feet of wire.
- 2 -U bolts with nuts.
- 1- Mounting bracket.
- \* Power Relays (as required)

# Electronic Water Level Management Systems

## SENSOR ASSEMBLY INSTALLATION

The Waterline WLC2000 through WLC6000 should be mounted in a convenient location where water spray will not impinge upon the unit and at a height consistent with figure 2. The unit and the input/output cabling must be securely attached to the mounting surface. The sensor cable should be installed in a grounded metal conduit in order to prevent spurious signals from interfering with the sensor operation.

The sensor assembly (see Figure 2) must be mounted so that the end of the PVC pipe is below the minimum water level that is to be maintained. Secure the probe assembly to a suitable mounting surface with the correct size "U" (U20P5-9) bolts and the mounting bracket (M20P5-9). Be careful to insure that the top portion of the assembly is not in contact with the water and that the "U" (U20P5-9) bolts are above the high water level. Note: There are two small 1/8 inch vent holes near the top of the housing in the PVC pipe. Make certain these vent holes are not obstructed in any way. They must be clear in order for the sensor assembly to function properly.

The probe assembly is supplied such that it has the sensor cable pre-installed. Route the cable along an appropriate location and determine if the length needs to be shortened. The wire may be cut to a shorter length if required.

NOTE: THE SENSOR WIRES MUST NOT BE SPLICED IN ORDER TO INCREASE THE LENGTH.

Fasten the wire to a water tight PVC compression connector and then install into the bottom of the Waterline WLC2000 through WLC6000 housing. The output control wires are connected to the relays output terminals using (1/4 inch spade) connector supplied by the user. NOTE: the rating on the relay should not be exceeded.

Use water tight PVC conduit for all connections and route the location desired by the end user.

If the depth of the probes need to be seen while the sensor assembly is installed mark the sensor probe levels on the outside of the pipe with a "Sharpie". The center of the nominal fill level is marked with a black button in the outer pipe.

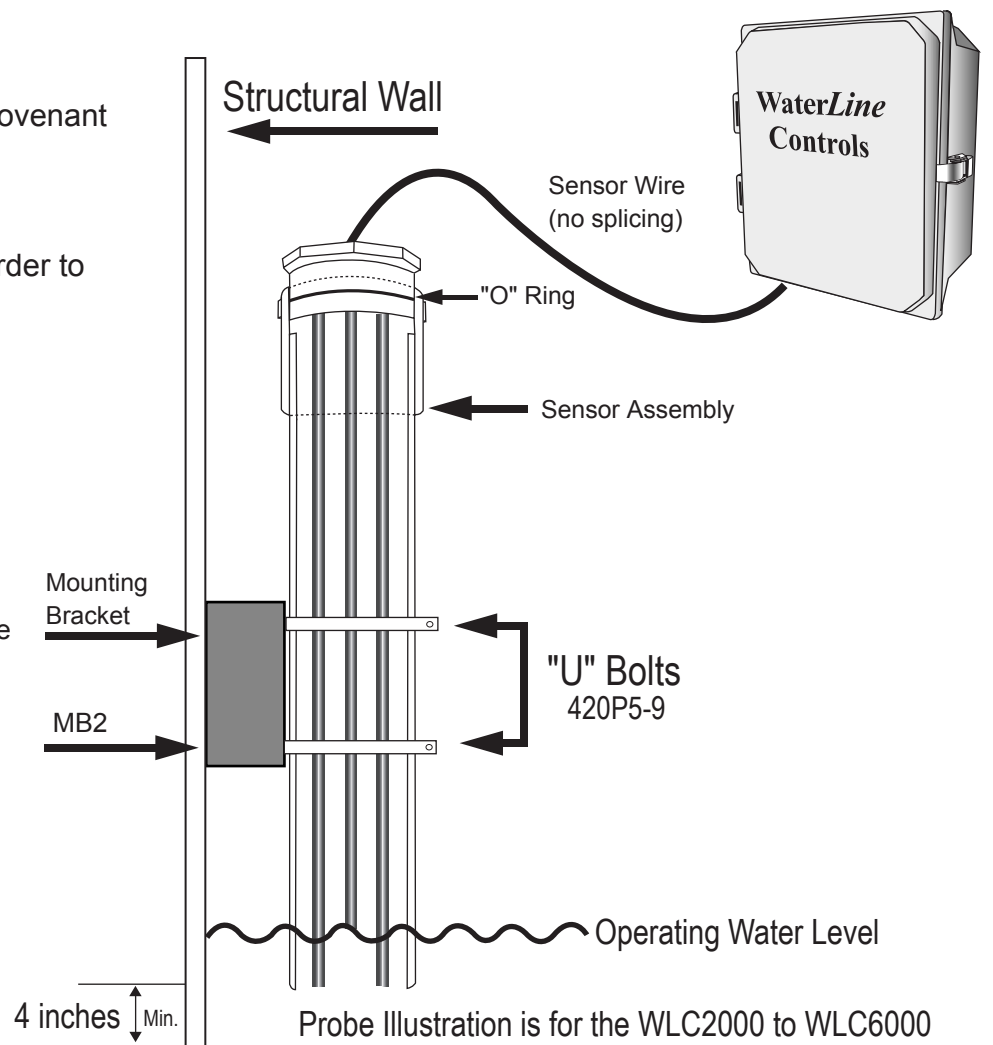

WIRE COLOR CODES vs NUMBER OF CONDUCTORS		
PROBE DESIGN		
WIRE COLOR vs PROBE LENGTH	LENGTH	LEVEL FUNCTION
Black	17"	Ground
Blue	17"	HCO
Brown	16 3/8"	LA
White	15 1/2"	ON
Red	14"	OFF
Green	9 1/2"	HA

**WLC6000 "FILL"**  
Function, Color codes for Probes

Misc Data: • PVC length = 18 1/4"  
• Vent = 1/8" from bottom of PVC  
• Button = 2 1/4" from bottom of PVC  
• Button Size = 3/16"  
• With a "Test" Function

Figure 2.

# Electronic Water Level Management Systems

## TEST INSTRUCTIONS

The following test procedure will test the electronics and output relay functions. The test verifies all of the electronics from the location of the sensor wire connection to the PCB through the output relays. It verifies the functions of the Waterline WLC3000 through WLC6000.

THIS TEST IS VALID FOR THE WLC3000 THROUGH THE WLC6000. IT IS NOT A FUNCTION FOR THE WLC2000.

To initiate the test, perform the following:

1. Press the "PRESS TO TEST" push button momentarily. The yellow LED will light and remain on until the "test function" is completed.
2. The controller automatically sequences through the functions.

Note: once the "PRESS TO TEST" button is depressed the test sequence cannot be interrupted. This test will take approximately 2 minutes.

The functions of the LED's, the power relays and the indicator relays are shown in the following truth tables.

### TESTING TRUTH TABLE

TEST SEQUENCE	HEAT CUT OUT	LOW ALARM	MAKE UP ON	HIGH ALARM
1	ACTIVATED	ACTIVATED	ACTIVATED	OFF
2	OFF	ACTIVATED	ACTIVATED	OFF
3	OFF	OFF	ACTIVATED	OFF
4	OFF	OFF	ACTIVATED	OFF
5	OFF	OFF	OFF	OFF
6	OFF	OFF	OFF	ACTIVATED
7	OFF	OFF	OFF	OFF
8	OFF	OFF	OFF	OFF
9	OFF	OFF	ACTIVATED	OFF
10	OFF	ACTIVATED	ACTIVATED	OFF
11	ACTIVATED	ACTIVATED	ACTIVATED	OFF

### FUNCTION TRUTH TABLE

MODEL	HEAT CUT OUT	LOW ALARM	HIGH ALARM	FILL	TEST FUNCTION
WLC6000	YES	YES	YES	YES	YES
WLC5000	NO	YES	YES	YES	YES
WLC4500	NO	YES	NO	YES	YES
WLC4000	NO	NO	YES	YES	YES
WLC3000	NO	NO	NO	YES	YES
WLC2000	NO	NO	NO	YES	NO

### DEFINITIONS

**HEAT CUT OUT:** The water level is below the safe operating level.

**LOW ALARM:** The water level is approaching the unsafe level.

**MAKE UP ON:** The system is calling for water to be added.

**HIGH ALARM:** The water level is approaching the maximum allowed level.

### BUILDING AUTOMATION DRY CONTACTS

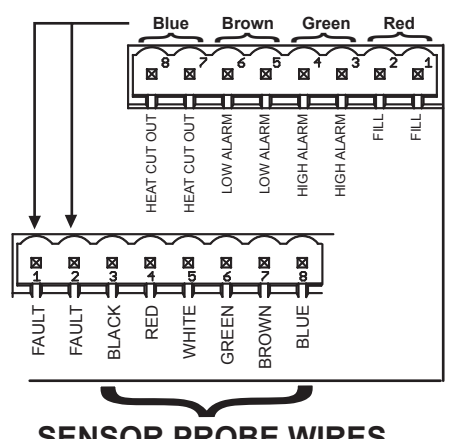

The "Dry Contacts" are included in the design of the WaterLine Controller as an aid to the proper controlling of the building automation system.

Their function is as follows:

For each controller function (for example the WLC6000) HEAT CUT OUT, LOW ALARM, FILL, and HIGH ALARM there is a corresponding "Dry Contact" that changes from an open circuit to a closed circuit whenever the corresponding relay is activated. The Dry Contacts are rated at 50 VDC @ 0.25 Amp. Other controller series may have a different number of Dry Contacts but they always have the same number as the number of relays; thereby affording the proper signals to be made available to the building automation system.

The Fault contacts tell the operator when the unit has filled for six hours or if the sensors have debris on them.